

APPENDIX A  
PARTICIPANT DEMOGRAPHICS

### Male and Female Distribution per Condition<sup>1</sup>

Count		Conditions						Total
		A	B	C	D	E	F	
gender	male	6	7	6	8	7	7	41
	female	14	13	14	12	13	13	79
Total		20	20	20	20	20	20	120

<sup>1</sup>Note. Total number of cases per condition. Letters associated with the hypertext conditions are as follows: A = (12 x 27); B = (11 x 5 x 5); C = (4 x 4 x 4 x 4); D = (6 x 2 x 2 x 12); E = (3 x 2 x 2 x 2 x 12); F = (2 x 3 x 2 x 3 x 2 x 3).

### Amount of Participant Schooling per Condition<sup>1</sup>

Count		Conditions						Total
		A	B	C	D	E	F	
year in school	freshman	11	9	10	9	7	4	50
	sophomore	6	5	4	7	6	7	35
	junior	1	4	2	1	2	1	11
	senior	2	2		3	4	4	15
	graduate						2	2
	other			4		1	2	7
Total		20	20	20	20	20	20	120

<sup>1</sup>Note. Total number of cases per condition. Letters associated with the hypertext conditions are as follows: A = (12 x 27); B = (11 x 5 x 5); C = (4 x 4 x 4 x 4); D = (6 x 2 x 2 x 12); E = (3 x 2 x 2 x 2 x 12); F = (2 x 3 x 2 x 3 x 2 x 3).

### Frequency of Computer Use per Condition<sup>1</sup>

Count		Conditions						Total
		A	B	C	D	E	F	
Frequently use Computer	daily	12	10	13	17	11	14	77
	few times per week	7	8	5	3	7	6	36
	few times per month	1	2	2		1		6
	less than once per month					1		1
Total		20	20	20	20	20	20	120

<sup>1</sup>Note. Total number of cases per condition. Letters associated with the hypertext conditions are as follows: A = (12 x 27); B = (11 x 5 x 5); C = (4 x 4 x 4 x 4); D = (6 x 2 x 2 x 12); E = (3 x 2 x 2 x 2 x 12); F = (2 x 3 x 2 x 3 x 2 x 3).

### Computer Use Hours per Week per Condition<sup>1</sup>

Count		Conditions						Total
		A	B	C	D	E	F	
hrs per week	0 - 1 hr per week	1	4			3		8
on Computer	2 - 6 hrs per week	11	9	10	9	6	8	53
	7 - 14 hrs per week	3	4	4	9	5	6	31
	14 - 24 hrs per week	3	1	3		2	2	11
	25 - 40 hrs per week	2	1	2	1	4	1	11
	more than 40		1	1	1		3	6
Total		20	20	20	20	20	20	120

<sup>1</sup>Note. Total number of cases per condition. Letters associated with the hypertext conditions are as follows: A = (12 x 27); B = (11 x 5 x 5); C = (4 x 4 x 4 x 4); D = (6 x 2 x 2 x 12); E = (3 x 2 x 2 x 2 x 12); F = (2 x 3 x 2 x 3 x 2 x 3).

### Primary Computer Use per Condition<sup>1</sup>

Conditions	N						
	word processing	spreadsheets	games	financial	browsing	email	other
A	14	2	6	4	13	16	5
B	19	1	11		16	17	5
C	14	1	9	5	15	17	7
D	18	2	8	1	14	17	4
E	18	3	5	3	17	18	6
F	12	2	5	1	14	16	11
Total	95	11	44	14	89	101	38

<sup>1</sup>Note. Total number of cases per condition. Letters associated with the hypertext conditions are as follows: A = (12 x 27); B = (11 x 5 x 5); C = (4 x 4 x 4 x 4); D = (6 x 2 x 2 x 12); E = (3 x 2 x 2 x 2 x 12); F = (2 x 3 x 2 x 3 x 2 x 3).

### Frequency of Visiting Web per Condition<sup>1</sup>

Count		Conditions						Total
		A	B	C	D	E	F	
frequently	daily	8	7	8	9	10	8	50
visit Web	few times per week	9	6	7	10	5	9	46
	few times per month	3	6	3	1	4	3	20
	less than once a month		1	1		1		3
	never			1				1
Total		20	20	20	20	20	20	120

<sup>1</sup>Note. Total number of cases per condition. Letters associated with the hypertext conditions are as follows: A = (12 x 27); B = (11 x 5 x 5); C = (4 x 4 x 4 x 4); D = (6 x 2 x 2 x 12); E = (3 x 2 x 2 x 2 x 12); F = (2 x 3 x 2 x 3 x 2 x 3).

### Hours of Web Usage per Condition<sup>1</sup>

Count		Conditions						Total
		A	B	C	D	E	F	
hrs of web usage	0-1hrs	6	8	2	2	4	2	24
	2-6 hrs	10	7	11	10	7	13	58
	7-14 hrs	1	3	5	6	5	2	22
	14-24 hrs	3	1	1	1	2	1	9
	24-40		1		1	2	1	5
	over 40 hrs						1	1
Total		20	20	19	20	20	20	119

<sup>1</sup>Note. Total number of cases per condition. Letters associated with the hypertext conditions are as follows: A = (12 x 27); B = (11 x 5 x 5); C = (4 x 4 x 4 x 4); D = (6 x 2 x 2 x 12); E = (3 x 2 x 2 x 2 x 12); F = (2 x 3 x 2 x 3 x 2 x 3).

### Primary use of Web per Condition<sup>1</sup>

N										
Conditions	education	shopping	product info	entertainment	work/business	communication	personal needs	browsing	other	
A	10	7	8	13	4	6	9	14		
B	16	6	7	12	4	5	6	13	2	
C	14	4	6	10	3	7	11	11	2	
D	15	7	7	12	4	9	13	14		
E	15	5	9	11	2	11	13	13	2	
F	14	3	6	11	5	6	9	12		
Total	84	32	43	69	22	44	61	77	6	

<sup>1</sup>Note. Total number of cases per condition. Letters associated with the hypertext conditions are as follows: A = (12 x 27); B = (11 x 5 x 5); C = (4 x 4 x 4 x 4); D = (6 x 2 x 2 x 12); E = (3 x 2 x 2 x 2 x 12); F = (2 x 3 x 2 x 3 x 2 x 3).

### Reported Problems Using the Web per Condition<sup>1</sup>

N											
Conditions	not finding info	can't organize	can't find page	can't return to page	lost	can't visualize where to go	takes too long	costs too much	links not working	other	
A	7	3	11	9	3	2	12	2	13	1	
B	14	4	8	6	3	1	13	1	12	2	
C	11	2	12	5	1	2	10	3	16		
D	10	3	6	5			11		12		
E	11	4	11	5	3	1	6	1	15		
F	9		5	2		1	10	2	16	1	
Total	62	16	53	32	10	7	62	9	84	4	

<sup>1</sup>Note. Total number of cases per condition. Letters associated with the hypertext conditions are as follows: A = (12 x 27); B = (11 x 5 x 5); C = (4 x 4 x 4 x 4); D = (6 x 2 x 2 x 12); E = (3 x 2 x 2 x 2 x 12); F = (2 x 3 x 2 x 3 x 2 x 3).

### Bought Items from Web in Last Year per Condition<sup>1</sup>

Count		Conditions						Total
		A	B	C	D	E	F	
how often	never	8	10	8	7	6	10	49
buy from	once	2	3	2	5	5	4	21
web in	2 - 5 times	8	6	7	4	6	3	34
last yr	6 - 15 times	1	1	2	1	2	2	9
	15 - 30 times	1			2	1	1	5
	more than 30 times				1			1
Total		20	20	19	20	20	20	119

<sup>1</sup>Note. Total number of cases per condition. Letters associated with the hypertext conditions are as follows: A = (12 x 27); B = (11 x 5 x 5); C = (4 x 4 x 4 x 4); D = (6 x 2 x 2 x 12); E = (3 x 2 x 2 x 2 x 12); F = (2 x 3 x 2 x 3 x 2 x 3).

### Reported Use of Internet for Fun/Explore per Condition<sup>1</sup>

Count		Conditions						Total
		A	B	C	D	E	F	
Use	Most of the time	8	5	5	8	6	7	39
Internet to	Sometimes	10	13	11	11	9	11	65
explore	Seldom	2	2	3		3	1	11
	Never					2	1	3
	22.00				1			1
Total		20	20	19	20	20	20	119

<sup>1</sup>Note. Total number of cases per condition. Letters associated with the hypertext conditions are as follows: A = (12 x 27); B = (11 x 5 x 5); C = (4 x 4 x 4 x 4); D = (6 x 2 x 2 x 12); E = (3 x 2 x 2 x 2 x 12); F = (2 x 3 x 2 x 3 x 2 x 3).

### Reported Use of Internet for Information per Condition<sup>1</sup>

Count		Conditions						Total
		A	B	C	D	E	F	
Use Internet	Most of the time	6	9	9	9	6	10	49
to find info	Sometimes	13	10	10	10	13	8	64
	Seldom	1	1		1	1	2	6
Total		20	20	19	20	20	20	119

<sup>1</sup>Note. Total number of cases per condition. Letters associated with the hypertext conditions are as follows: A = (12 x 27); B = (11 x 5 x 5); C = (4 x 4 x 4 x 4); D = (6 x 2 x 2 x 12); E = (3 x 2 x 2 x 2 x 12); F = (2 x 3 x 2 x 3 x 2 x 3).

### Reported Comfort with Using Internet per Condition<sup>1</sup>

Count		Conditions						Total
		A	B	C	D	E	F	
How comfortable w/Internet	Very comfortable	7	8	8	10	10	8	51
	Somewhat comfortable	9	9	8	8	7	12	53
	Neither comfortable nor uncomfortable	3	2	2	2	1		10
	Somewhat uncomfortable	1	1	1		2		5
Total		20	20	19	20	20	20	119

<sup>1</sup>Note. Total number of cases per condition. Letters associated with the hypertext conditions are as follows: A = (12 x 27); B = (11 x 5 x 5); C = (4 x 4 x 4 x 4); D = (6 x 2 x 2 x 12); E = (3 x 2 x 2 x 2 x 12); F = (2 x 3 x 2 x 3 x 2 x 3).

### Reported Satisfaction with Internet Skills per Condition<sup>1</sup>

Count		Conditions						Total
		A	B	C	D	E	F	
How satisfied w/Internet	Very Satisfied		4	2	3	2	3	14
	Somewhat Satisfied	13	12	10	15	13	14	77
	Neither satisfied nor unsatisfied	4	2	3	2	2	3	16
	Somewhat unsatisfied	2	2	4		3		11
	Very unsatisfied	1						1
Total		20	20	19	20	20	20	119

Letters associated with the hypertext conditions are as follows: A = (12 x 27); B = (11 x 5 x 5); C = (4 x 4 x 4 x 4); D = (6 x 2 x 2 x 12); E = (3 x 2 x 2 x 2 x 12); F = (2 x 3 x 2 x 3 x 2 x 3).

APPENDIX B

PRE- AND POST-EXPERIMENT QUESTIONNAIRES

Pre-Experiment Questionnaire

Background Questionnaire

---

Sex: \_\_\_ Male \_\_\_ Female

Age: \_\_\_\_\_

School Year: \_\_\_ Freshman \_\_\_ Sophomore \_\_\_ Jr. \_\_\_ Sr. \_\_\_ Graduate \_\_\_ Other

Major: \_\_\_\_\_ Minor: \_\_\_\_\_

1. How frequently do you use a computer?

- Daily
- A few times per week
- A few times per month
- Less than once per month
- Never (If never, skip the rest of the questions and see experimenter)

2. On average, how many hours a week do you use a computer?

- 0 to 1 hours per week
- 2 to 6 hours per week
- 7 to 14 hours per week
- 14 to 24 hours per week
- 25 to 40 hours per week
- Over 40 hours per week

3. What do you primarily use a computer for?

*(Please check all that apply)*

- Word processing
- Spreadsheets
- Games
- Financial
- Browsing the World Wide Web
- E-mail
- Other (please specify) \_\_\_\_\_

4. How frequently do you visit web sites (on the World Wide Web or internet)?

- Daily
- A few times per week
- A few times per month
- Less than once per month
- Never (If never, skip the rest of the questions and see experimenter)

5. On average, how many hours a week do you use the Web?

- 0 to 1 hours per week
- 2 to 6 hours per week
- 7 to 14 hours per week
- 14 to 24 hours per week
- 25 to 40 hours per week
- Over 40 hours per week

**PLEASE TURN PAGE**

6. What do you primarily use the Web for? *(Please check all that apply)*
- Education
  - Shopping
  - Gathering product information (i.e., on potential shopping items)
  - Entertainment
  - Work/Business
  - Communication with others (not including e-mail)
  - Gathering information for personal needs
  - Browsing or "surfing the Web" (i.e., playing around)
  - Other (please specify) \_\_\_\_\_
7. What do you find to be the biggest problems in using the Web in general?  
*(Please check all that apply.)*
- Not being able to find the information I am looking for
  - Not being able to efficiently organize the information I gather
  - Not being able to find a page I know is out there
  - Not being able to able to return to a page I once visited
  - Not being able to determine where I am (i.e., lost in hyperspace)
  - Not being able to visualize where I have been and where I can go
  - It takes too long to view/download pages
  - It cost too much
  - Encountering links that do not work
  - Other (please specify) \_\_\_\_\_
8. How often have you bought items from the Web in the last year?
- Never
  - Once
  - 2 to 5 times
  - 6 to 15 times
  - 15 to 30 times
  - Over 30 times in the last year
9. To what extent would you say you use the Internet to have "fun" and explore?
- Most of the time
  - Sometimes
  - Seldom
  - Never
10. To what extent would you say you use the Internet to search for specific information?
- Most of the time
  - Sometimes
  - Seldom
  - Never
11. How comfortable do you feel using the Internet?
- Very comfortable
  - Somewhat comfortable
  - Neither comfortable nor uncomfortable
  - Somewhat uncomfortable
  - Very uncomfortable
12. How satisfied are you with your current skills for using the Internet?
- Very satisfied - I can do everything that I want to do
  - Somewhat satisfied - I can do most things I want to do
  - Neither satisfied nor unsatisfied
  - Somewhat unsatisfied - I can't do many things I would like to do
  - Very unsatisfied - I can't do most things I would like to do





APPENDIX C

EXPLICIT AND IMPLICIT TASK QUESTION ITEMS

### *Explicit Tasks*

- 1) You would like to purchase a new sports coat for your father.
- 2) You would like to purchase a pair of tube socks for your 12-year-old son.
- 3) You would like to purchase some baseball equipment for your friend who is now playing for WSU.
- 4) You would like to purchase a posturpedic pillow for your father's king-sized bed.
- 5) You would like to purchase a pair of sandals for your mother.
- 6) You would like to purchase a single-person tent for your hiking trip next week.
- 7) You would like to purchase a Barbie doll for your 8-year-old niece.
- 8) You would like to buy some fragrant soap for your bathroom.
- 9) You would like to buy a new microwave oven.
- 10) You would like to get a new copper gardening basket for your patio.
- 11) You would like to get a new leather recliner for your house
- 12) You would like to buy some new pajamas for your 10-year-old daughter for this winter.

### *Implicit Tasks*

- 13) Your father does a great deal of business travel. It is important that he appear neatly groomed for all of his late meetings. He often has a five o'clock shadow. You would like to buy him something useful for his business trips.
- 14) Your friends are about to get married. You know that they like elegant and formal dining. However, this is difficult to do at their home with only having plastic plates. You would like to buy something very nice for them that they would both like.
- 15) A friend of yours is retiring from the place where you work. You know that he loves food smoked over an open fire. However, he does not have the means to do this. You and your friends would like to buy him a nice gift that he would like.
- 16) You just bought a new house that has several nice big trees in the backyard. The weather has been very nice and you would like to lounge by the trees and read a book in the backyard. However, you have nothing to lie on. You would, therefore, like to purchase something that would allow you to do this.
- 17) Your 10-year-old nephew's shoes have several holes in it. You would like to have him all dressed up for the upcoming rodeo, which he loves so much because he wants to be a cowboy. You would like to find the most appropriate item that will please him.

- 18) Your father's birthday is coming up and you know he does a lot of out outside chores during the wintertime, but often complains about his fingers getting numb. You would like to find the most appropriate item that will please him.
- 19) Your sister, who is 25, is going to the opera in New York and she would like something very nice to wear. Help her find something appropriate to wear.
- 20) You just converted a bedroom into a new office for you. However, you do not have anything to place your computer on. You would like to buy something that would fix this.
- 21) Your daughter is about to graduate from elementary school. You would like to buy her a gift. You know she has been collecting the new quarters that have been minted recently. You would like to find something that will please her.
- 22) Your brother moved into a new house. His children liked the old house because it had lots of trees to climb and swing on. Unfortunately, the backyard of the new house does not have any trees. You would like to buy something they would like for the outside that would be almost as good as trees.
- 23) You would like to get more information on how to loose some weight before your Florida vacation next month. You would like to find something that would allow you to do this.
- 24) You would like to remodel part of your kitchen from an older style that only had storage space for plates and glasses. You love to drink a glass of wine during your meals. However, the current design does not allow any place to put wine. You would like to furnish your kitchen so you could stock it full of wine.

APPENDIX D

PILOT STUDY FORM EXAMPLE



APPENDIX E

CALCULATION OF METRIC FOR HYPERTEXT CONDITIONS

## The Calculation of the $H_{HAI}$ Predictive Values for the Hypertext Conditions

### *The HAI Scores for the (12 x 27) Structure*

Using the HAI formula:  $H_{HAI} = \sqrt{\sum [\sum \log_2(b_{n+1})][\log_2(d_{nl+1})]_{n_1..n_\infty}}$

**1<sup>st</sup> level**  $\rightarrow (\log_2 1+12) = 3.70$ ; so,  $3.70(\text{weight of } 1) = 3.70$

**2<sup>nd</sup> level**  $\rightarrow (\log_2 1+27)+(\log_2 1+27)+(\log_2 1+27)+(\log_2 1+27)+(\log_2 1+27)+$

$(\log_2 1+27)+(\log_2 1+27)+(\log_2 1+27) +(\log_2 1+27)+(\log_2 1+27)+(\log_2 1+27)+(\log_2 1+27) = 57.6$ ;

so,  $57.6(\text{weight of } 1) = 57.7$

$\Sigma 3.70 + 57.6 = 61.72$ ; Therefore,  $\sqrt{61.42} = 7.84$  bits associated with information uncertainty for this hypertext topology.

### *The HAI Scores for the (11 x 5 x 5) Structure*

**1<sup>st</sup> level**  $\rightarrow (\log_2 1 + 11) = 3.58$ ; so,  $3.58(\text{weight of } 1) = 3.58$

**2<sup>nd</sup> level**  $\rightarrow (\log_2 1+5)+(\log_2 1+5)+(\log_2 1+5)+(\log_2 1+5)+ (\log_2 1+5)+(\log_2 1+5)+$

$(\log_2 1+5)+(\log_2 1+5)+ (\log_2 1+5)+(\log_2 1+5)+(\log_2 1+5)= 28.4$ ;

so,  $28.4(\text{weight of } 1.58) = 40.32$

**3<sup>rd</sup> level**  $\rightarrow (\log_2 1+5)+(\log_2 1+5)+(\log_2 1+5)+(\log_2 1+5)+ (\log_2 1+5)+(\log_2 1+5)+$

$(\log_2 1+5)+(\log_2 1+5)+(\log_2 1+5)+(\log_2 1+5)+ (\log_2 1+5)+(\log_2 1+5)+(\log_2 1+5)+$

$(\log_2 1+5)+(\log_2 1+5)+(\log_2 1+5)+ (\log_2 1+5)+(\log_2 1+5)+(\log_2 1+5)+(\log_2 1+5)+$

$(\log_2 1+5)+(\log_2 1+5)+(\log_2 1+5)+ (\log_2 1+5)+(\log_2 1+5)+(\log_2 1+5)+(\log_2 1+5)+$

$(\log_2 1+5)+(\log_2 1+5)+(\log_2 1+5)+ (\log_2 1+5)+(\log_2 1+5)+(\log_2 1+5)+(\log_2 1+5)+$

$(\log_2 1+5)+(\log_2 1+5)+(\log_2 1+5)+ (\log_2 1+5)+(\log_2 1+5)+(\log_2 1+5)+(\log_2 1+5)+$

$(\log_2 1+5)+(\log_2 1+5)+(\log_2 1+5)+ (\log_2 1+5)+(\log_2 1+5)+(\log_2 1+5)+(\log_2 1+5)+$

$(\log_2 1+5)+(\log_2 1+5)+(\log_2 1+5)+ (\log_2 1+5)+(\log_2 1+5)+(\log_2 1+5)+(\log_2 1+5)= 141.9$ ;

$\Sigma 3.58 + 40.32 + 141.9 = 185.80$ ; Therefore,  $\sqrt{185.80} = 13.63$  bits associated with information uncertainty for this hypertext topology

*The HAI Scores for the (4 x 4 x 4 x 4) Structure*

**1<sup>st</sup> level** →  $(\log_2 1 + 4) = 2.32$ ; so  $2.32(\text{weight of } 1) = 2.32$

**2<sup>nd</sup> level** →  $(\log_2 1+4)+(\log_2 1+4)+(\log_2 1+4)+(\log_2 1+4) = 9.28$ ; so,  $9.28(\text{weight of } 1.58) = 14.66$

**3<sup>rd</sup> level** →  $(\log_2 1+4)+(\log_2 1+4)+(\log_2 1+4)+(\log_2 1+4)+(\log_2 1+4)+(\log_2 1+4)+$   
 $(\log_2 1+4)+(\log_2 1+4)+(\log_2 1+4)+(\log_2 1+4)+(\log_2 1+4)+(\log_2 1+4)+(\log_2 1+4)+$   
 $(\log_2 1+4)+(\log_2 1+4)+(\log_2 1+4) = 37.12$ ; so,  $37.12(\text{weight of } 2) = 74.24$

**4<sup>th</sup> level** →  $(\log_2 1+4)+(\log_2 1+4)+(\log_2 1+4)+(\log_2 1+4)+(\log_2 1+4)+(\log_2 1+4)+$   
 $(\log_2 1+4)+(\log_2 1+4)+(\log_2 1+4)+(\log_2 1+4)+(\log_2 1+4)+(\log_2 1+4)+(\log_2 1+4)+$   
 $(\log_2 1+4)+(\log_2 1+4)+(\log_2 1+4)+(\log_2 1+4)+(\log_2 1+4)+(\log_2 1+4)+(\log_2 1+4)+$   
 $(\log_2 1+4)+(\log_2 1+4)+(\log_2 1+4)+(\log_2 1+4)+(\log_2 1+4)+(\log_2 1+4)+(\log_2 1+4)+$   
 $(\log_2 1+4)+(\log_2 1+4)+(\log_2 1+4)+(\log_2 1+4)+(\log_2 1+4)+(\log_2 1+4)+(\log_2 1+4)+$   
 $(\log_2 1+4)+(\log_2 1+4)+(\log_2 1+4)+(\log_2 1+4)+(\log_2 1+4)+(\log_2 1+4)+(\log_2 1+4)+$   
 $(\log_2 1+4)+(\log_2 1+4)+(\log_2 1+4)+(\log_2 1+4)+(\log_2 1+4)+(\log_2 1+4)+(\log_2 1+4)+$   
 $(\log_2 1+4)+(\log_2 1+4) = 148.48$ ; so,  $148.48(\text{weight of } 1) = 148.48$

$\Sigma 2.32 + 14.66 + 74.24 + 148.48 = 239.70$ ; Therefore,  $\sqrt{239.70} = 15.00$  bits associated with information uncertainty for this hypertext topology.

*The HAI Scores for the (6 x 2 x 2 x 12) Structure*

**1<sup>st</sup> level** →  $(\log_2 1+6) = 2.81$ ; so,  $2.81(\text{weight of } 1) = 2.81$

**2<sup>nd</sup> level** →  $(\log_2 1+2)+(\log_2 1+2)+(\log_2 1+2)+(\log_2 1+2)+(\log_2 1+2)+(\log_2 1+2) = 9.48$ ; so,  
 $9.48(\text{weight of } 1.58) = 14.98$

**3<sup>rd</sup> level** →  $(\log_2 1+2)+(\log_2 1+2)+(\log_2 1+2)+(\log_2 1+2)+(\log_2 1+2)+(\log_2 1+2)$   
 $(\log_2 1+2)+(\log_2 1+2)+(\log_2 1+2)+(\log_2 1+2)+(\log_2 1+2)+(\log_2 1+2)= 18.96$ ; so,  $18.96(\text{weight of } 2) = 37.92$

**4<sup>th</sup> level** →  $(\log_2 1+12)+(\log_2 1+12)+(\log_2 1+12)+(\log_2 1+12)+(\log_2 1+12)+(\log_2 1+12)+(\log_2$   
 $1+12)+(\log_2 1+12)+(\log_2 1+12)+(\log_2 1+12)+(\log_2 1+12)+(\log_2 1+12)+(\log_2 1+12)+$   
 $(\log_2 1+12)+(\log_2 1+12)+(\log_2 1+12)+(\log_2 1+12)+(\log_2 1+12)+(\log_2 1+12)+(\log_2 1+12)+$   
 $(\log_2 1+12)+(\log_2 1+12)+(\log_2 1+12)+(\log_2 1+12)$ ; So,  $88.80(\text{weight of } 1) = 88.80$





APPENDIX F  
DEMONSTRATING THE  $H_{\text{HAI}}$  METRIC

To demonstrate the utility of this metric, three hypertext typology examples with the same number of 40 nodes and four levels of depth are shown. Thus, the only part of the structure that was varied was the clustering of the nodes. These structures were chosen because they could not be examined for information accessibility by using current methods of analysis.

*Example 1*

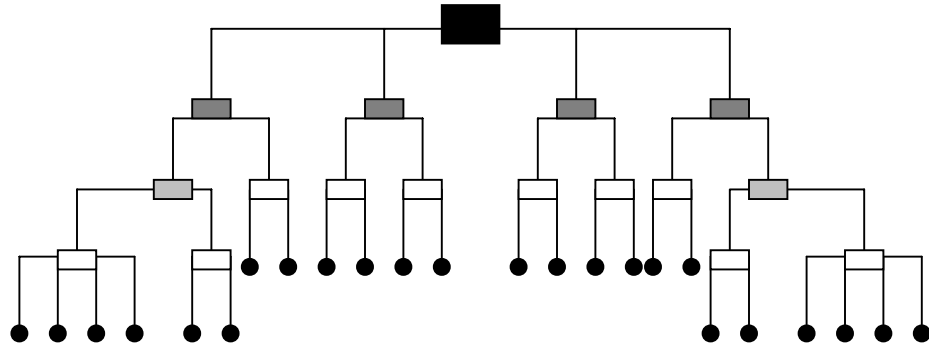

Using the  $H_{HAI}$  formula:  $\sqrt{\sum [\sum \log_2(b_{n+1})][\log_2(d_{nl+1})]_{n_1..n_\infty}}$

**1<sup>st</sup> level**  $\rightarrow (\log_2 4+1) = 2.32$

**2<sup>nd</sup> level**  $\rightarrow (\log_2 2+1)+(\log_2 2+1)+(\log_2 2+1)+(\log_2 2+1) = 6.32$ ; So,  $6.32(\text{weight } 1.58) = 9.99$

**3<sup>rd</sup> level**  $\rightarrow (\log_2 2+1)+(\log_2 2+1) = 3.16$ ; So,  $3.16(\text{weight } 2) = 6.32$

**4<sup>th</sup> level**  $\rightarrow (\log_2 4+1)+(\log_2 2+1)+(\log_2 2+1)+(\log_2 2+1)+(\log_2 2+1)+(\log_2 2+1)+(\log_2 2+1)+(\log_2 2+1)+(\log_2 2+1)+(\log_2 4+1) = 17.28$ ; So,  $17.28(\text{weight } 1) = 17.28$

$\sum 2.32 + 9.99 + 6.32 + 17.28 = 35.91$ ; Therefore,  $\sqrt{35.91} = 5.99$  bits associated with information uncertainty for this hypertext topology.

Example 2

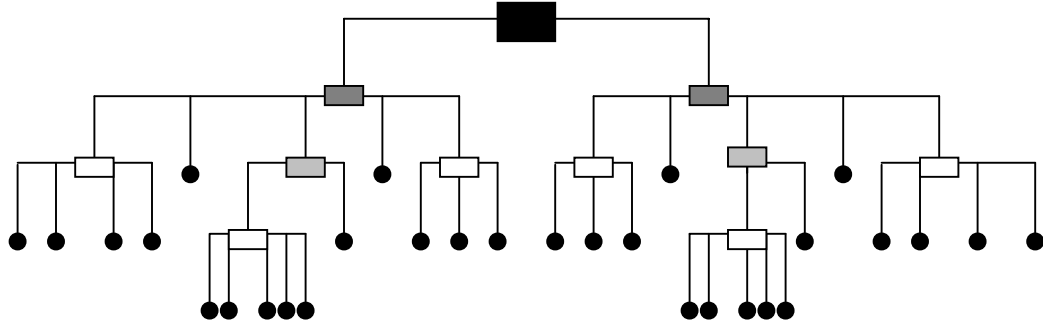

Using the  $H_{HAI}$  formula:  $\sqrt{\sum [\sum \log_2(b_{n+1})][\log_2(d_{nl+1})]_{n_1..n_\infty}}$

**1<sup>st</sup> level**  $\rightarrow (\log_2 2+1) = 1.58$

**2<sup>nd</sup> level**  $\rightarrow (\log_2 5+1)+(\log_2 5+1) = 5.16$ ; So,  $5.16(\text{weight } 1.58) = 8.2$

**3<sup>rd</sup> level**  $\rightarrow (\log_2 2+1)+(\log_2 2+1) = 3.16$ ; So,  $3.16(\text{weight } 2) = 6.32$

**4<sup>th</sup> level**  $\rightarrow (\log_2 4+1)+(\log_2 5+1)+(\log_2 3+1)+(\log_2 3+1)+(\log_2 5+1)+(\log_2 4+1) = 13.8$ ; So,  
 $13.8(\text{weight } 1) = 13.8$ ,

$\sum 1.58 + 8.2 + 6.32 + 13.8 = 29.9$ ; Therefore,  $\sqrt{29.9} = 5.47$  bits associated with information uncertainty for this hypertext topology.



APPENDIX G

EXTENSIONS OF THE  $H_{\text{HAI}}$  PREDICTIVE MODEL

### *Modifications to the Current Metric*

*Considering the total number of nodes with a hypertext.* A potential limitation of the  $H_{HAI}$  metric is that it does not take into account the total number of nodes in the hypertext structure being assessed. As discussed previously, the greater the number of nodes, the greater degree of structural complexity within the hypertext itself. Consequently, a predictive  $H_{HAI}$  value may have somewhat different meanings depending on whether the hypertext structure is large or small. If the  $H_{HAI}$  value is low and the structure is small, then the hypertext may reflect relatively low amounts of information accessibility. However, if the structure is large—which would typically produce relatively larger  $H_{HAI}$  values—having a comparatively small  $H_{HAI}$  value would indicate that the hypertext is proportionally high in information accessibility.

To allow for a more accurate description of a hypertext's information accessibility when the overall hypertext size is considered, the  $H_{HAI}$  value can be converted to a  $H_{HAI(ToT)}$  value, which is simply a monotonic transformation of the predictive  $H_{HAI}$  value that accounts for hypertext size. This can be expressed as

$$H_{HAI(ToT)} = \frac{(H_{HAI})(5) - H_{MAX}}{5} \quad (8)$$

where both the  $H_{HAI}$  value and the total number of nodes within the structure are considered. This is accomplished by multiplying the obtained  $H_{HAI}$  value by 5, minus the  $H_{MAX}$ , which is the  $\log_2 n$  of the total number of nodes within the entire hypertext structure. Accordingly, the  $H_{MAX}$  is the maximum amount of possible information that would be conveyed by a given number of equiprobable alternatives within an optimal structure. The resulting value is then divided by 5 to produce the  $H_{HAI(ToT)}$  value. The use of 5 as a weight was intended to eliminate the possibility of obtaining a negative value if  $H_{MAX}$  had a larger value than the  $H_{HAI}$  value, which could occur in smaller, less complex hypertext structures. This particular weight was chosen because it produces the appropriate change in uncertainty associated with different number values of the total nodes

within various hypertext structures. However the exact weight that is ultimately chosen is an empirical question that will need to be addressed in future studies.

The use of  $\log_2 n$  to account for the increase in the number of total nodes within a hypertext corresponds to the tenets of information theory in that the rise in the number of options available—in this case, node choices—produces increases in uncertainty that rise logarithmically with the number of options. For example, if the  $H_{HAI}$  value of a hypertext structure was 12.83 and the total number of nodes was 400 ( $H_{MAX}$  would then be, 8.64 bits), the resulting  $H_{HAI(ToT)}$  value would be 11.10 bits. If instead the total number of nodes was 900, then the  $H_{HAI(ToT)}$  value would be 10.87 bits. It should be noted that since the difference in the number of nodes between conditions in the present study was negligible, consequently a transformation was not needed, and therefore was not used.

#### *Using the $H_{HAI}$ Model for Unequal Probabilities*

The current  $H_{HAI}$  metric is generally intended to be a model that can help predict search performance of a proposed hypertext structure. However, it would also be beneficial to be able to compare the hypertext structure that is ultimately derived by the predictive model to the actual search performance of that structure over the course of some period of time, and after many users have traversed through its structure.

Any hypertext may be faced with many variables that can affect the search performance of the structure. One of the most potent variables is the information itself. That is to say, the information within the hypertext may obstruct or draw the attention of the user to particular information paths, and thus not all nodes will be accessed with the same degree of frequency. Consequently, each node will have different (unequal) probabilities of being accessed. For example, a hyperlink furcating a node that addresses information that is considered to be not important to most users will not be accessed nearly as often as a hyperlink furcating to a node that is considered to have pertinent information by many users. Thus, these two nodes will have unequal probabilities of being accessed.

For this reason, an extension of the  $H_{HAI}$  metric that takes into account the unequal probabilities associated with the selection of each node within a hypertext structure is introduced as the  $H_{HAI(unequal)}$  metric. To determine the  $H_{HAI(unequal)}$  equation, the probability mean percentage of each node for an existing hypertext is ascertained. This is done by calculating the number of times each hyperlink furcation within the hypertext structure was accessed over a period of time. The resulting numbers are then divided by the total number of times all hyperlink furcations within that hypertext structure were assessed for that same time period. This will generate the probability ( $p$ ) values. The  $\log_2 1/p$  of each value is then derived for each hyperlink furcation within each node. Each derived  $\log_2 1/p$  value within a particular node is then multiplied by the original  $p$  value for that node. The resulting ( $b_{unequal}$ ) outcome is simply the sum of these values for each node. This is computed as

$$b_{unequal} = \sum p \left[ \log_2 \left( \frac{1}{p} \right) \right] \quad (9)$$

The  $b_{unequal}$  outcome is then put back in the original equation and the metric is computed in essentially the same manner as the  $H_{HAI}$  metric with equal probability. Specifically, the sum of  $b_{unequal}$  for each node cluster is multiplied by the specific weight for that level. The square root of the sum of the resulting numbers produces the  $H_{HAI(unequal)}$  value for that hypertext. This is computed as

$$H_{HAI(unequal)} = \sqrt{\sum [(b_{unequal(n+1)})][\log_2 (d_{n+1})]_{n_1..n_\infty}} \quad (10)$$

This extension of the  $H_{HAI}$  metric has yet to be empirically examined. Nevertheless, the  $H_{HAI(unequal)}$  metric does abide by the same principles as the  $H_{HAI}$  metric. Therefore, it is asserted that the  $H_{HAI(unequal)}$  metric should be an accurate tool in assessing the information accessibility of hypertext structures after the selection probabilities for each information path is known.

After more research is done, the use of both metrics together may prove to be beneficial in assessing hypertext structure. Since the  $H_{HAI}$  metric is a predictive model, it could serve to help in the design of hypertext structures by generating predictive values for various hypertext prototypes. The prototype with the most informationally efficient structure could therefore be determined and implemented. The  $H_{HAI(unequal)}$  metric could, in turn, serve to assess the hypertext structure after some period of time by taking into account the popularity of information paths throughout the structure.

APPENDIX H

CONTENT ARRANGEMENT OF THE  
HYPERTEXT CONDITIONS

*The (12 x 27) Hypertext Condition*

**1st Level**

- A. Men's Apparel**
- B. Women's Apparel**
- C. Boy's Apparel**
- D. Girl's Apparel**
- E. Bedroom**
- F. Kitchen**
- G. Furniture/Entertainment**
- H. Bathroom**
- I. Sports**
- J. Fitness/The Outdoors**
- K. For the Backyard**
- L. Toys**

**2<sup>nd</sup> Level**

- A.**
  - 1. Suits**
  - 2. Sports Coats**
  - 3. Trousers**
  - 4. Long-sleeve Shirts**
  - 5. Polo Shirts**
  - 6. Casual Shorts**
  - 7. Casual Pants**
  - 8. Summer Pajamas**
  - 9. Winter Pajamas**
  - 10. Tube Socks**
  - 11. Athletic Socks**
  - 12. Plaid Dress Socks**
  - 13. Classic Colors Dress Socks**
  - 14. V-neck Undershirts**
  - 15. Crewneck Undershirts**
  - 16. Summer Pajamas**
  - 17. Winter Pajamas**
  - 18. Boxer Shorts**
  - 19. Sports Briefs**
  - 20. Regular Briefs**
  - 21. Dress Shoes**
  - 22. Sandals**
  - 23. Casual Shoes**
  - 24. Athletic Shoes**
  - 25. Cowboy Boots**
  - 26. Gloves**
  - 27. Hats**
  - 28. Scarves**
  - 29. Sweaters**

**B**

- 1. Business suits and dresses**
- 2. Prom dresses**
- 3. Evening dresses**
- 4. Long-sleeve shirts**

5. Polo shirts
6. Dockers casual shorts
7. Casual skirts and pants
8. Leather pumps
9. Casual shoes
10. Sandals
11. Athletic shoes
12. Leather boots
13. Gloves
14. Hats
15. Scarves
16. Sweaters
17. Button-down sweaters
18. Full-length slippers
19. Half-length slippers
20. Low cut panties
21. High cut panties
22. Girdles
23. Boxers
24. Pantyhose
25. Athletic socks
26. Pajamas
27. Pajamas
28. Pajamas

## C

1. Cotton Blend school coats
2. Wool Blend school Coats
3. Suits
4. Long-sleeve
5. Polo shirts
6. Casual shorts
7. Casual pants
8. Summer pajamas
9. Winter Pajamas
10. Dress shoes
11. Sandals
12. Casual shoes
13. Athletic shoes
14. Cowboy boots
15. Gloves
16. Hats
17. Pullover sweaters
18. Button down sweaters
19. Winter scarves
20. V-neck undershirts
21. Crewneck undershirts
22. Tube Socks
23. Athletic Socks
24. Classic Colors dress socks
25. Plaid Dress socks
26. Boxer shorts
27. Sports briefs
28. Regular briefs

## **D**

- 1) Cotton/Wool Blend school coats
- 2) Cotton/Silk Blend dresses
- 3) Cotton/Silk Blend suits
- 4) Long-sleeve
- 5) Polo shirts
- 6) Casual shorts & Skirts
- 7) Pants
- 8) Leather pumps
- 9) Sandals
- 10) Casual shoes
- 11) Athletic shoes
- 12) Leather boots
- 13) Gloves
- 14) Hats
- 15) Scarves
- 16) Sweaters
- 17) Full-length slippers
- 18) Half-length slippers
- 19) Panties
- 20) Boxers
- 21) Slimmers
- 22) Pantyhose
- 23) Athletic socks
- 24) Low cut socks
- 25) Summer pajamas
- 26) Winter pajamas
- 27) Cotton/Silk pajamas

## **E**

- 1) Decorative bed sheets
- 2) Classic colors bed sheets
- 3) Kid's cartoon bed sheets
- 4) Decorative bed skirts
- 5) Classic colors bed skirts
- 6) Kid's cartoon bed skirts
- 7) Decorative bed shams
- 8) Kid's cartoon bed shams
- 9) Classic colors shams
- 10) Decorative comforters
- 11) Classic colors comforters
- 12) Decorative quilts
- 13) Classic colors quilts
- 14) Air mattresses
- 15) Coil mattresses
- 16) Box springs – King/Queen sizes
- 17) Box springs – Double/Single sizes
- 18) Convertible Beds – King/Queen sizes
- 19) Convertible Beds –Double/Single sizes
- 20) Foam pads and pillows- King/Queen sizes
- 21) Foam pads and pillows- double/single sizes
- 22) Goosedown pillows- King/Queen sizes
- 23) Goosedown pillows- Double/Single sizes
- 24) Posturepedic pillows- Double/Single sizes
- 25) Posturepedic pillows- King/Queen sizes
- 26) Posturepedic pads

**27) Goosedown pads**

**F**

- 1) **Cutlery holders**
- 2) **Electric knives and accessories**
- 3) **Steak knives**
- 4) **Pairing, Cleavers, and carving knives**
- 5) **Silver/Stainless steel flatware**
- 6) **Waterford Fine China and Crystal**
- 7) **Pots and pans**
- 8) **Baking measuring set**
- 9) **French bistro cooking set**
- 10) **Serve-n-store bakeware set**
- 11) **Cookware sets and accessories**
- 12) **Electric Juicers**
- 13) **Electric mixers**
- 14) **Electric toasters**
- 15) **Electric blenders**
- 16) **Electric stick Mixers**
- 17) **Kitchen stoves**
- 18) **Kitchen refrigerators**
- 19) **Kitchen microwave ovens**
- 20) **Kitchen dishwashers**
- 21) **Kitchen ovens**
- 22) **Expandable kitchen tables**
- 23) **China cabinets**
- 24) **Wine cabinets**
- 25) **Kitchen stools**
- 26) **Kitchen chairs**
- 27) **Kitchen storage island**

**G**

- 1) **Leather Sofas**
- 2) **Cloth sofas**
- 3) **Leather Sleepers**
- 4) **Cloth Sleepers**
- 5) **Traditional leather love seats**
- 6) **Traditional cloth love seats**
- 7) **Traditional Oak desks**
- 8) **Modern oak desks**
- 9) **Secretary desks**
- 10) **Computer/Office desks**
- 11) **Oak Dining room tables**
- 12) **Glass dining room tables**
- 13) **Glass living room tables**
- 14) **End tables**
- 15) **Coffee tables**
- 16) **Side tables**
- 17) **Leather chairs**
- 18) **Cloth chairs**
- 19) **Leather recliners**
- 20) **Cloth recliners**
- 21) **Leather dining room chairs**
- 22) **Cloth dining room chairs**
- 23) **Televisions**
- 24) **VCRs and DVD players**

- 25) **Television/VCR combos**
- 26) **Stereos**
- 27) **Movie DVDs/CDs**

## **H**

- 1) **Classic colors Bathroom towels**
- 2) **Patterned Bathroom towels**
- 3) **Plaid Bathroom towels**
- 4) **Classic colors hand cloths**
- 5) **Plaid hand cloths**
- 6) **Patterned hand cloths**
- 7) **Classic colors bathroom mats**
- 8) **Patterned bathroom mats**
- 9) **Classic colors contoured bath mats**
- 10) **Patterned contoured bath mats**
- 11) **Bathroom towel racks**
- 12) **Medicine cabinets**
- 13) **Bathroom chairs**
- 14) **Bathroom mirrors**
- 15) **Hand soaps**
- 16) **Moisturizing soaps**
- 17) **Fragrant soaps**
- 18) **Hair shampoos**
- 19) **Body shampoos**
- 20) **Men's electric shavers**
- 21) **Men's shaving lotion**
- 22) **Women's electric shavers**
- 23) **Women's shaving lotion**
- 24) **Hairdryers**
- 25) **Curling irons**
- 26) **Combs/brushes**
- 27) **Electric/non-electric toothbrushes**

## **I**

- 1) **Basketball equipment**
- 2) **Football equipment**
- 3) **Baseball equipment**
- 4) **Softball equipment**
- 5) **Soccer equipment**
- 6) **Volleyball equipment**
- 7) **Golf equipment**
- 8) **Pool table equipment**
- 9) **Table tennis**
- 10) **Darts equipment**
- 11) **Foosball equipment**
- 12) **Racquetball equipment**
- 13) **Swimming equipment**
- 14) **Pool equipment and accessories**
- 15) **Water skiing**
- 16) **Surfing equipment**
- 17) **Water sports equipment**
- 18) **Kids T-ball**
- 19) **Kids softball/Baseball equipment**
- 20) **Soccer equipment**
- 21) **Basketball equipment**
- 22) **Kids protective T-ball**

- 23) Kids protective softball gear
- 24) Kids protective basketball gear
- 25) Kids protective soccer gear
- 26) In-Line/Roller Skating equipment

## **J**

- 1) Weight-lifting books
- 2) Fat burning books
- 3) Kids beginning books on sports/fitness
- 4) Exercise books for children with disabilities
- 5) Gym sets
- 6) Free-weight sets
- 7) Abdominal machines
- 8) Weight accessories
- 9) Exercise mats
- 10) Racing bikes
- 11) In-line and roller skates
- 12) Mountain bikes
- 13) Men's touring bikes
- 14) Women's touring bikes
- 15) Aerobic videos
- 16) Tai-bo videos
- 17) Abdominal videos
- 18) Children's fun-aerobic videos
- 19) Exercise videos for preschoolers
- 20) Mountain climbing gear
- 21) Single/multi-person tents
- 22) 50 & 80 pound backpacks
- 23) Water purifiers & lighting
- 24) Hiking/mountain climbing maps
- 25) Hunting rifles/knives
- 26) Fishing rods/reels
- 27) Hunting/fishing outfits
- 28) Fishing gear

## **K**

- 1) Outdoor floor swings
- 2) Outdoor rope swings
- 3) Kids teeter totters
- 4) Play forts
- 5) Play houses
- 6) Two-person trampolines
- 7) Four-person trampolines
- 8) Jungle gyms
- 9) Lawn darts
- 10) Lawn croquet
- 11) Gas barbecue grills
- 12) Electric barbecue grills
- 13) Kettle barbecue grills
- 14) Grill covers
- 15) Rotisseries
- 16) Patio chairs
- 17) Patio tables
- 18) Hammocks
- 19) Patio umbrellas
- 20) Gardening tools

- 21) Annuals garden seeds
- 22) Perennials garden seeds
- 23) Annual flowers
- 24) Perennial flowers
- 25) Wicker garden baskets
- 26) Copper garden baskets

## **L**

- 1) Gameboy
- 2) Playstation
- 3) Electric riding toys
- 4) Remote-controlled toys
- 5) Video games
- 6) Interactive toys
- 7) Electronic board games
- 8) Coin collecting kits
- 9) Stamp collecting kits
- 10) Paint/drawing sets
- 11) Kid's telescopes
- 12) Kid's microscopes
- 13) Infant/developmental toys
- 14) Teddy bears
- 15) Outdoor infant toys
- 16) Bath toys
- 17) Board games
- 18) Barbie dolls
- 19) Action movie figures
- 20) Movie character figures
- 21) Army toys
- 22) Big wheel
- 23) Toy cars
- 24) Books for young children
- 25) Books for post-elementary children
- 26) Music for children
- 27) Movies for the family
- 28) Movies for young children

*The (11 x 5 x 5) Hypertext Condition*

**1st Level**

- A) Men's Apparel**
- B) Women's Apparel**
- C) Boy's Apparel**
- D) Girl's Apparel**
- E) Bed & Bath**
- F) Kitchen**
- G) Furnishings**
- H) Sports**
- I) Fitness/The Outdoors**
- J) For the Backyard**
- K) Toys**

**2nd Level**

**A**

- 1) Clothing outfits**
- 2) Footwear**
- 3) Undergarments**
- 4) Socks & sleepwear**
- 5) Winter accessories**

**B**

- 1) Clothing outfits**
- 2) Footwear**
- 3) Undergarments**
- 4) Hosiery/socks & sleepwear**
- 5) Winter accessories**

**C**

- 1) Clothing outfits**
- 2) Footwear**
- 3) Undergarments**
- 4) Socks & sleepwear**
- 5) Winter accessories**

**D**

- 1) Clothing Outfits**
- 2) Footwear**
- 3) Undergarments**
- 4) Socks & sleepwear**
- 5) Winter accessories**

**E**

- 1) Bed linens**
- 2) Beds & accessories**
- 3) Bathroom linens/Furniture**
- 4) Bathroom toiletries**
- 5) Grooming accessories**

## **F**

- 1) **Cutlery**
- 2) **Table/Kitchenware**
- 3) **Hand-held appliances**
- 4) **Large appliances**
- 5) **Furnishings**

## **G**

- 1) **Sofas**
- 2) **Chairs**
- 3) **Desks**
- 4) **Tables**
- 5) **Home Electronics**

## **H**

- 1) **Outdoor sports**
- 2) **Indoor sports**
- 3) **Water sports**
- 4) **Bikes/Skates**
- 5) **Children's sports/fitness**

## **I**

- 1) **Exercise Equipment**
- 2) **Fitness books & videos**
- 3) **Children's fitness books & videos**
- 4) **Camping**
- 5) **Hunting/Fishing**

## **J**

- 1) **Playgrounds**
- 2) **Grilling**
- 3) **Gardening**
- 4) **Patio furniture**
- 5) **Backyard lawn items**

## **K**

- 1) **Electronic/video games**
- 2) **Hobbies/crafts,**
- 3) **Educational/science**
- 4) **Toys & games**
- 5) **Books, music, & movies**

## **3rd Level**

### **A1**

- i) **Suits**
- ii) **Sports Coats/Trousers**
- iii) **Long-sleeve/Polo shirts**
- iv) **Causal shorts**
- v) **Casual pants**

### **A2**

- i) **V-neck undershirts**
- ii) **Crewneck undershirts**
- iii) **Boxer shorts**
- iv) **Sports briefs**

- i) Regular briefs**
- A3**
- i) Tube/athletic socks**
  - ii) Classic colors dress socks**
  - iii) Plaid dress socks**
  - iv) Summer Pajamas**
  - v) Winter Pajamas**
- A4**
- i) Dress shoes**
  - ii) Sandals**
  - iii) Casual shoes**
  - iv) Athletic shoes**
  - v) Cowboy boots**
- A5**
- i) Gloves**
  - ii) Hats**
  - iii) Scarves**
  - iv) Pullover sweaters**
  - vi) Button-down sweaters**
- B1**
- i) Business dresses & suits**
  - ii) Evening/prom dresses**
  - iii) Long-sleeve/Polo shirts**
  - iv) Casual shorts and skirts**
  - v) Casual pants**
- B2**
- i) Full-length slips**
  - ii) Half-length slips**
  - iii) Panties**
  - iv) Girdles**
- B3**
- i) Pantyhose**
  - ii) Athletic socks**
  - iii) Nightgowns**
  - iv) Summer pajamas**
  - v) Winter pajamas**
- B4**
- i) Leather pumps**
  - ii) Casual shoes**
  - iii) Sandals**
  - iv) Athletic shoes**
  - v) Leather boots**
- B5**
- i) Gloves**
  - ii) Hats**
  - iii) Scarves**
  - iv) Pullover sweaters**
  - v) Button-down sweaters**

- C1**
- i) **School coats**
- ii) **Suits**
- iii) **Long-sleeve/Polo shirts**
- iv) **Casual pants**
- v) **Casual shorts**
  
- C2**
- i) **V-neck undershirts**
- ii) **Crewneck undershirts**
- iii) **Boxer shorts**
- iv) **Sports briefs**
- v) **Regular briefs**
  
- C3**
- i) **Tube and athletic socks**
- ii) **Classic colors dress socks**
- iii) **Plaid dress socks**
- iv) **Summer Pajamas**
- v) **Winter Pajamas**
  
- C4**
- i) **Dress shoes**
- ii) **Sandals**
- iii) **Casual shoes**
- iv) **Athletic shoes**
- v) **Cowboy boots**
  
- C5**
- i) **Gloves**
- ii) **Hats**
- iii) **Pullover sweaters**
- iv) **Scarves**
- v) **Button down sweaters**
  
- D1**
- i) **School coats**
- ii) **Dresses & suits**
- iii) **Long-sleeve and Polo shirts**
- iv) **Casual pants**
- v) **Casual shorts/skirts**
  
- D2**
- i) **Full-length slips**
- ii) **Half-length slips**
- iii) **Panties**
- iv) **Boxers**
- v) **Girdles**
  
- D3**
- i) **Pantyhose**
- ii) **Athletic socks**
- iii) **Nightgowns**
- iv) **Summer pajamas**
- v) **Winter pajamas**

- D4**
- i) Leather pumps**
  - ii) Sandals**
  - iii) Casual shoes**
  - iv) Athletic shoes**
  - v) Leather boots**
- D5**
- i) Gloves**
  - ii) Hats**
  - iii) Pullover sweaters**
  - iv) Button down sweaters**
  - v) Scarves**
- E 1**
- i) Classic colors bed sheets**
  - ii) Decretive & cartoon bed sheets**
  - iii) Bed shams**
  - iv) Quilts**
  - v) Comforters**
- E2**
- i) Air/Coil Mattresses**
  - ii) Box spring & convertible Mattresses**
  - iii) Mattress pads**
  - iv) Goosedown & foam pillows**
  - v) Posturepedic pillows**
- E3**
- i) Bathroom towels**
  - ii) Hand cloths**
  - iii) Bathroom mats**
  - iv) Towel Racks/Cabinets**
  - v) Bathroom Chairs/Mirrors**
- E4**
- i) Moisturizing soaps**
  - ii) Body shampoos**
  - iii) Hair shampoos**
  - iv) Hand soaps**
  - v) Fragrant soaps**
- E5**
- i) Men's shavers & accessories**
  - ii) Women's shavers & accessories**
  - iii) Hairdryers/curling irons**
  - iv) Electronic/non-electric toothbrushes**
  - v) Combs/hairbrushes**
- F1**
- i) Cutlery holders**
  - ii) Electric knives and accessories**
  - iii) Steak knives**
  - iv) Carving knives**
  - v) Silver and Stainless steel flatware**

- F2**  
i) **Waterford Fine China and Crystal**  
ii) **Pots and pans**  
iii) **French bistro cooking set**  
iv) **Serve-n-store bakeware set**  
v) **Cookware, baking measuring sets and accessories**

- F3**  
i) **Electric Pocket Mixers**  
ii) **Electric mixers**  
iii) **Electric blenders**  
iv) **Electric Stick Blenders**

- F4**  
i) **Kitchen stoves**  
ii) **Kitchen refrigerators**  
iii) **Kitchen microwave ovens**  
iv) **Kitchen dishwashers**  
v) **Kitchen ovens**

- F5**  
i) **Expandable kitchen tables**  
ii) **China cabinets**  
iii) **Wine cabinets**  
iv) **Kitchen stools and chairs**  
v) **Kitchen storage island**

- G1**  
i) **Leather sofas**  
ii) **Leather love seats**  
iii) **Cloth sofas**  
iv) **Cloth love seats**  
v) **Leather & Cloth sleeper sofas**

- G2**  
i) **Leather chairs**  
ii) **Cloth**  
iii) **Leather recliners**  
iv) **Cloth recliners**  
v) **Living/dining room chairs**

- G3**  
i) **Traditional Oak/Teak desks**  
ii) **Modern Oak/Teak desks**  
iii) **Modern glass desks**  
iv) **Secretary desks**  
v) **Office desks**

- G4**  
i) **Dining room tables**  
ii) **Glass tables**  
iii) **End tables**  
iv) **Coffee tables**  
v) **Side tables**

- G5**
- i) Televisions**
  - ii) VCRs and DVD players**
  - iii) Television/VCR combos**
  - iv) Stereos**
  - v) Movie DVSS and CDs**
- H1**
- i) Basketball equipment**
  - ii) Football equipment**
  - iii) Baseball and softball equipment**
  - iv) Soccer and volleyball equipment**
  - v) Golf equipment**
- H2**
- i) Pool table equipment**
  - ii) Table tennis**
  - iii) Darts equipment**
  - iv) Foosball equipment**
  - v) Racquetball equipment**
- H3**
- i) Swimming equipment**
  - ii) Pool equipment and accessories**
  - iii) Water skiing**
  - iv) Surfing equipment**
  - v) Water sports equipment**
- H4**
- i) Racing bikes**
  - ii) In-line and roller skates**
  - iii) Mountain bikes**
  - iv) Men's touring bikes**
  - v) Women's touring bikes**
- H5**
- i) Kids T-ball/softball equipment**
  - ii) Soccer equipment**
  - iii) Basketball equipment**
  - iv) Kids protective T-ball/softball gear**
  - i) Skating equipment**
- I1**
- i) Gym sets**
  - ii) Free-weight sets**
  - iii) Abdominal machines**
  - iv) Weight accessories**
  - v) Exercise mats**
- I2**
- i) Aerobic videos**
  - ii) Tai-bo videos**
  - iii) Abdominal videos**
  - iv) Weight-lifting books**
  - v) Fat-Burning books**

- I3**
- ii) **Children’s fun-aerobic videos**
  - iii) **Exercise books for children with physical Disabilities**
  - iv) **Exercise videos for preschoolers**
  - v) **Kids beginning books on sports**
  - i) **Kids beginning books on fitness**
- I4**
- vi) **Hunting rifles**
  - i) **Hunting knives**
  - ii) **Fishing rods and reels**
  - iii) **Hunting and Fishing outfits**
  - v) **Fishing gear**
- I5**
- vi) **Mountain climbing maps**
  - ii) **Single and Multi-person tents**
  - iii) **50 and 80 pound backpacks**
  - iv) **Cooking, water, and lighting equipment**
  - iv) **Hiking and mountain climbing maps**
- J1**
- i) **Outdoor swings**
  - ii) **Kids teeter totters**
  - iii) **Play houses**
  - iv) **Trampolines**
  - v) **Jungle-gyms**
- J2**
- i) **Gas barbecue Grills**
  - ii) **Electric barbecue Grills**
  - iii) **Smoker barbecue grills**
  - iv) **Grill covers and rotisseries**
  - v) **Kettle barbecue grills**
- J3**
- i) **Gardening tools**
  - ii) **Gardening seeds**
  - iii) **Garden flowers**
  - iv) **Wicker garden baskets**
  - v) **Copper garden baskets**
- J4**
- i) **Patio chairs**
  - ii) **Patio tables**
  - iii) **Hammocks**
  - iv) **Patio umbrellas**
- J5**
- i) **Lawn darts**
  - ii) **Lawn Croquet**
  - iii) **Lawn gnomes**
  - iv) **Lawn globes**
  - v) **Lawn lighting**

- K1**
- i) Gameboy, Sony Playstation, and video games**
  - ii) Electric riding toys**
  - iii) Remote controlled toys**
  - iv) Interactive toys**
  - v) Electronic board games**

- K2**
- i) Stamp collecting kits**
  - ii) Toy trains**
  - iii) Coin collecting kits**
  - iv) Paint and drawing sets**
  - v) Art easels**

- K3**
- i) Kids telescopes**
  - ii) Kids microscopes**
  - iii) Discovery ant forms**
  - iv) Discovery Jr. science labs**
  - v) Discovery Jr. electronic lab**

- K4**
- i) Action/movie character figures**
  - ii) Army toys, toy cars, and trucks**
  - iii) Bath toys**
  - iv) Big Wheel**
  - v) Barbies, teddy bears, and action figures**

- K5**
- i) Books for young children**
  - ii) Books for post-elementary children**
  - iii) Music for children**
  - iv) Movies for the family**
  - v) Movies for Young children**

*The (4 x 4 x 4 x 4) Hypertext Condition*

**1st Level**

- A) Male Apparel**
- B) Female Apparel**
- C) Home Interiors**
- D) Leisure/Outdoor/Fitness**

**2nd Level**

**A**

- 1) Men's clothing & accessories**
- 2) Men's sleepwear & Undergarments**
- 3) Boy's Clothing & Accessories**
- 4) Boy's Sleepwear & Undergarments**

**B**

- 1) Women's Clothing & Accessories**
- 2) Women's Sleepwear & Undergarments**
- 3) Girl's Clothing & Accessories**
- 4) Girl's Sleepwear & Undergarments**

**C**

- 1) Bedroom**
- 2) Bathroom**
- 3) Kitchen**
- 4) Furniture/Entertainment**

**D**

- 1) Sports**
- 2) Fitness/The Outdoors**
- 3) Backyard Fun**
- 4) Toys**

**3rd Level**

**A1**

- a) Formal Outfits**
- b) Causal Cloths**
- c) Footwear**
- d) Winter Accessories**

**A2**

- a) Sleepwear**
- b) Undershirts**
- c) Underwear**
- d) Socks**

**A3**

- a) Formal Outfits**
- b) Causal Cloths**
- c) Footwear**
- a) Winter Accessories**

**A4**

- a) **Sleepwear**
- b) **Undershirts**
- c) **Underwear**
- d) **Socks**

**B1**

- a) **Formal Outfits**
- b) **Casual Cloths**
- c) **Footwear**
- d) **Winter Accessories**

**B2**

- a) **Sleepwear**
- b) **Slips**
- c) **Underwear**
- d) **Pantyhose/Socks**

**B3**

- a) **Formal Outfits**
- b) **Casual Cloths**
- c) **Footwear**
- d) **Winter Accessories**

**B4**

- a) **Sleepwear**
- b) **Slips**
- c) **Underwear**
- d) **Hosiery/Socks**

**C1**

- a) **Bedding linens**
- b) **Pillows**
- c) **Comforter & quilts**
- d) **Mattresses & accessories**

**C2**

- a) **Bathroom Linens**
- b) **Toiletries**
- c) **Bathroom Furniture**
- d) **Grooming Accessories**

**C3**

- a) **Cutlery**
- b) **Table/Kitchenware**
- c) **Appliances**
- d) **Furniture/Storage**

**C4**

- a) **Seating**
- b) **Desks**
- c) **Tables**
- d) **Home Electronics**

**D1**

- a) **Outdoor & Team Sports**
- b) **Water & Indoor Sports**
- c) **Bike & Skates**
- d) **Children's Exercise/Fitness**

**D2**

- a) **Adults Exercise/Fitness**
- b) **Exercise/Fitness Books & Videos**
- e) **Camping**
- c) **Hunting/fishing**

**D3**

- a) **Playgrounds**
- b) **Grilling**
- c) **Gardening**
- d) **Patio Furniture/Lawn Accessories**

**D4**

- a) **Electronic/Video Games**
- b) **Hobbies, Crafts, & Educational**
- c) **Toys & Games**
- d) **Kids' Books, Music, & Movies**

**4th Level**

**A1a**

- i) **Cotton Blend Suits**
- ii) **Wool Blend Suits**
- iii) **Sports Coats**
- iv) **Trousers**

**A1b**

- i) **Polo Shirts**
- ii) **Casual Shorts**
- iii) **Casual Long-sleeve Shirts**
- iv) **Casual Pants**

**A1c**

- i) **Dress Shoes**
- ii) **Casual Shoes & Sandals**
- iii) **Athletic Shoes**
- iv) **Cowboy Boots**

**A1d**

- i) **Gloves**
- ii) **Hats**
- iii) **Scarves**
- iv) **Sweaters**

**A2a**

- i) **Classic Colors Summer Pajamas**
- ii) **Plaid Summer Pajamas**
- iii) **Classic Colors Winter Pajamas**
- iv) **Plaid Winter Pajamas**

**A2b**

- i) Classic Colors V-neck Undershirts**
- ii) Plaid V-neck Undershirts**
- iii) Classic Colors Crewneck Undershirts**
- iv) Plaid Crewneck Undershirts**

**A2c**

- i) Silk Boxer Shorts**
- ii) Cotton Boxer Shorts**
- iii) Regular Briefs**
- iv) Sports Briefs**

**A2d**

- i) Tube Socks**
- ii) Athletic Socks**
- iii) Classic Colors Dress Socks**
- iv) Plaid Dress Socks**

**A3a**

- i) Cotton Blend School Coats**
- ii) Wool School Coats**
- iii) Cotton Blend dress Suits**
- iv) Wool Dress Suits**

**A3b**

- i) Polo Shirts**
- ii) Casual Shorts**
- iii) Long-sleeve Shirts**
- iv) Casual Pants**

**A3c**

- i) Dress Shoes**
- ii) Casual Shoes & Sandals**
- iii) Athletic Shoes**
- iv) Cowboy Boots**

**A3d**

- i) Gloves**
- ii) Hats**
- iii) Scarves**
- iv) Sweaters**

**A4a**

- i) Classic Colors Summer Pajamas**
- ii) Plaid Summer Pajamas**
- iii) Classic Colors Winter Pajamas**
- iv) Plaid Winter Pajamas**

**A4b**

- i) Classic Colors V-neck Undershirts**
- ii) Plaid V-neck Undershirts**
- iii) Classic Colors Crewneck Undershirts**
- iv) Plaid Crewneck Undershirts**

**A4c**

- i) Silk Boxer Shorts**
- ii) Cotton Boxer Shorts**
- iii) Athletic Briefs**
- iv) Regular Briefs**

**A4d**

- i) Tube Socks**
- ii) Athletic Socks**
- iii) Classic Colors Dress Socks**
- iv) Plaid Dress Socks**

**B1a**

- i) Business Dresses**
- ii) Evening Dresses**
- iii) Business Suits**
- iv) Prom Dresses**

**B1b**

- i) Polo Shirts**
- ii) Casual Shorts and Skirts**
- iii) Casual Long-sleeve Shirts**
- iv) Casual Pants**

**B1c**

- i) Leather Pumps**
- ii) Casual Shoes & Sandals**
- iii) Athletic Shoes**
- iv) Leather Boots**

**B1d**

- i) Gloves**
- ii) Hats**
- iii) Scarves**
- iv) Sweaters**

**B2a**

- i) Silk Nightgowns**
- ii) Cotton Nightgowns**
- iii) Summer Pajamas**
- iv) Winter Pajamas**

**B2b**

- i) Silk Full-length Slips**
- ii) Cotton Full-length Slips**
- iii) Silk Half-length Slips**
- iv) Cotton Half-length Slips**

**B2c**

- i) Low-cut Panties**
- ii) Hi-cut Panties**
- iii) Girdles**
- iv) Boxers**

**B2d**

- i) **Full-length Pantyhose**
- ii) **Half-length Pantyhose**
- iii) **Low-cut Athletic Socks**
- iv) **High-Cut Athletic Socks**

**B3a**

- i) **Cotton Blend School Coats**
- ii) **Wool Blend School Coats**
- iii) **Cotton Blend Dresses & Suits**
- iv) **Silk Blend Dresses & Suits**

**B3b**

- i) **Polo Shirts**
- ii) **Casual Shorts**
- iii) **Casual Skirts**
- iv) **Casual Pants**

**B3c**

- i) **Leather Pumps**
- ii) **Casual Shoes & Sandals**
- iii) **Athletic Shoes**
- iv) **Leather Boots**

**B3d**

- i) **Gloves**
- ii) **Hats**
- iii) **Scarves**
- iv) **Sweaters**

**B4a**

- i) **Silk Nightgowns**
- ii) **Cotton Nightgowns**
- iii) **Summer Pajamas**
- iv) **Winter Pajamas**

**B4b**

- i) **Silk Full-length Slips**
- ii) **Cotton Full-length Slips**
- iii) **Silk Half-length Slips**
- iv) **Cotton Half-length Slips**

**B4c**

- i) **Low-cut Panties**
- ii) **Hi-cut Panties**
- iii) **Boxers**
- iv) **Body Slimmers**

**B4d**

- i) **Full-length Pantyhose**
- ii) **Half-length Pantyhose**
- iii) **Athletic Socks**
- iv) **Low-cut Socks**

**C1 a**

- i) Classic Colors Bed Sheets/Shams**
- ii) Plaid Bed Sheets/Shams**
- iii) Decorative Bed Sheets/Shams**
- iv) Cartoon Bed Sheets/Shams**

**C1b**

- i) Firm Foam Pillows**
- ii) Soft Foam Pillows**
- iii) Goosedown Pillows**
- iv) Posturepedic Pillows**

**C1c**

- i) Silk Comforters**
- ii) Wool Comforters**
- iii) Cotton Quilts**
- iv) Wool Quilts**

**C1d**

- i) Air/Coil Mattresses**
- ii) Box spring Mattresses**
- iii) Convertible Mattresses**
- iv) Mattress Pads**

**C2a**

- i) Bathroom Towels**
- ii) Bathroom Mats**
- iii) Contoured Bath Mats**
- iv) Hand Cloths**

**C2b**

- i) Moisturizing & Fragrant Soaps**
- ii) Body Shampoos**
- iii) Shampoos**
- iv) Hand soaps**

**C2c**

- i) Bathroom Towel Racks**
- ii) Medicine Cabinets**
- iii) Bathroom Chairs**
- iv) Bathroom Mirrors**

**C2d**

- i) Men's Shavers & Accessories**
- ii) Women's Shavers & Accessories**
- iii) Hairdryers**
- iv) Electric/Non-electric Toothbrushes**

**C3a**

- i) Cutlery Holders**
- ii) Electric Knives & Accessories**
- iii) Flatware & Steak Knives**
- iv) Carving Knives**

- C3b**  
i) **Fine China**  
ii) **Fine Crystal**  
iii) **French Bistro & Serve-n-Store Bakeware**  
iv) **Pots & Pans**

- C3c**  
i) **Mixers & Juicers**  
ii) **Refrigerators**  
iii) **Dishwashers**  
iv) **Ovens/Stoves**

- C3d**  
i) **Expandable Tables**  
ii) **Kitchen Stools & Chairs**  
iii) **Wine & China Cabinets**  
iv) **Storage Islands**

- C4a**  
i) **Sofas/Sleepers**  
ii) **Chairs**  
iii) **Love Seats**  
iv) **Recliners**

- C4b**  
i) **Traditional Desks**  
ii) **Modern Desks**  
iii) **Computer/Office Desks**  
iv) **Secretary Desks**

- C4c**  
i) **Side/End Tables**  
ii) **Dining Room Tables**  
iii) **Corner Tables**  
iv) **Coffee Tables**

- C4d**  
i) **Televisions/DVD Players**  
ii) **VCRs & TV/VCR Combos**  
iii) **Stereos**  
iv) **Movie DVs and CDs**

- D1a**  
i) **Basketball & Football Equipment**  
ii) **Baseball & Softball Equipment**  
iii) **Golf Equipment**  
iv) **Soccer & Volleyball Equipment**

- D1b**  
i) **Swimming/Pool Equipment**  
ii) **Water Skiing/Surfing**  
iii) **Pool table & Foosball Tables**  
iv) **Table Tennis, Racquetball, & Darts**

**D1c**

- i) Mountain Bikes**
- ii) Racing Bikes**
- iii) Touring Bikes**
- iv) In-line/Roller Skates**

**D1d**

- i) Kids Sporting Equipment**
- ii) Kids Protective Gear**
- iii) Exercise Videos for Preschoolers/Physical Disabilities**
- iv) Kids Books on Sports/Fitness**

**D2a**

- i) Exercise Mats**
- ii) Free-Weights**
- iii) Abdominal-Machines & Accessories**
- iv) Gym Sets**

**D2b**

- i) Weight-Lifting Books**
- ii) Fat-Burning Books**
- iii) Aerobic Exercise/fitness Videos**
- iv) Tai-bo Videos**

**D2c**

- i) Water/Cooking Gear**
- ii) Single & Multi-Person Tents**
- iii) 50 & 80 Pound Backpacks**
- v) Hiking/Mountain Climbing Maps**

**D2d**

- i) Hunting Rifles**
- ii) Hunting Knives**
- iii) Fishing Rods & Reels**
- iv) Hunting/Fishing Outfits & Gear**

**D3a**

- i) Swings/Teeter-Totters**
- ii) Jungle-Gyms**
- iii) Play Houses**
- iv) Trampolines**

**D3b**

- i) Gas & Electric Barbecue Grills**
- ii) Smoker Barbecue Grills**
- iii) Kettle Barbecue Grills**
- iv) Grill Covers & Rotisseries**

**D3c**

- i) Gardening Tools**
- ii) Seeds**
- iii) Garden Flowers**
- iv) Copper Gardening Baskets**

**D3d**

- i) Lawn Ornaments**
- ii) Hammocks**
- iii) Lawn Darts & Croquet**
- iv) Chairs & Tables**

**D4a**

- i) Gameboys, Playstation, & Videos**
- ii) Electronic Board Games**
- iii) Interactive Toys**
- iv) Riding & Remote Control Toys**

**D4b**

- i) Coin/Stamp Collecting Kits**
- ii) Jr. Science Lab & Discovery Ant Forms**
- iii) Paint & Drawing Set**
- iv) Kids Telescopes/Microscopes**

**D4c**

- i) Big Wheels & Bath Toys**
- ii) Action Figures**
- iii) Army Toys & Cars**
- iv) Barbies & Teddy Bears**

**D4d**

- i) Books for Kids/Family**
- ii) Videos for Kids/Family**
- iii) DVD for Kids/Family**
- iv) Music for Kids/Family**

*The (6 x 2 x 2 x 12) Hypertext Condition*

**1st Level**

- A) Male apparel**
- B) Female apparel**
- C) Bed & Bath**
- D) Kitchen & Living room**
- E) Sports/exercise & the outdoors**
- F) Toys and backyard fun**

**2nd Level**

**A**

- 1) Men's apparel**
- 2) Boy's apparel**

**B**

- 1) Women's apparel**
- 2) Girl's apparel**

**C**

- 1) Bedding**
- 2) Bathroom**

**D**

- 1) Kitchen**
- 2) Furniture/Entertainment**

**E**

- 1) Sports**
- 2) Exercise/The Outdoors**

**F**

- 1) For the Backyard**
- 2) Toys and Games**

**3rd Level**

**A1**

- a) Clothing & accessories**
- b) Sleepwear & undergarments**

**B1**

- a) Sleepwear & undergarments**
- b) Clothing & accessories**

**A2**

- a) Clothing & accessories**
- b) Sleepwear & undergarments**

**B2**

- a) Sleepwear & undergarments**
- b) Clothing & accessories**

**C1**

- a) **Bedroom linen**
- b) **Beds & Accessories**

**C2**

- a) **Bathroom linen**
- b) **Bathroom accessories**

**D1**

- a) **Table/Kitchenware**
- b) **Kitchen appliances and furniture**

**D2**

- a) **Living room seating**
- b) **Living room desks, tables, and entertainment**

**E1**

- a) **Team, indoor, and water sports**
- b) **Kid's sports and bikes/skates**

**E2**

- a) **Exercise/fitness equipment**
- b) **Hiking/Climbing, and hunting/fishing**

**F1**

- a) **Playgrounds and outdoor grilling**
- b) **Gardening, patio furniture and accessories**

**G1**

- a) **Electronic/video games, hobbies, arts/crafts, and educational toys**
- b) **Toys, games, figures, books, music, and movies, for kids and family**

**4th Level**

**A1a**

- i) **Cotton/Wool Blend sports coat**
- ii) **Cotton/Wool Blend suits**
- iii) **Cotton/Wool Blend trousers**
- iv) **Long-sleeve and Polo shirts**
- v) **Causal shorts and pants**
- vi) **Oxford dress shoes**
- vii) **Casual shoes and sandals**
- viii) **Athletic shoes**
- ix) **Cowboy boots**
- x) **Hats and scarves**
- xi) **Sweaters**
- xii) **Gloves**

**A1b**

- i) **Classic colors v-neck undershirts**
- ii) **Patterned v-neck undershirts**
- iii) **Classic colors crewneck undershirts**
- iv) **Patterned crewneck undershirts**
- v) **Silk boxer shorts**
- vi) **Cotton boxers**
- vii) **Sports briefs**

- viii) Regular briefs
- ix) Athletic/tube socks
- x) Dress socks
- xi) Summer pajamas
- xii) Winter pajamas

**A2a**

- i) Winter Pajamas
- ii) Summer Pajamas
- iii) Patterned v-neck undershirts
- iv) Classic colors v-neck undershirts
- v) Patterned crewneck undershirts
- vi) Classic colors crewneck undershirts
- vii) Silk boxer shorts
- viii) Cotton boxer shorts
- ix) Sports briefs
- x) Regular briefs
- xi) Athletic and tube socks
- xii) Dress socks

**A1b**

- i) Cotton/Wool Blend school coats
- ii) Cotton/Wool Blend dress suits
- iii) Cotton/Wool Blend trousers
- iv) Long-sleeve and Polo shirts
- v) Casual pants and shorts
- vi) Dress shoes
- vii) Casual shoes and sandals
- viii) Athletic shoes
- ix) Cowboy boots
- x) Gloves
- xi) Hats and scarves
- xii) Sweaters

**B1a**

- i) Business dresses and suits
- ii) Evening and prom dresses
- iii) Long-sleeve
- iv) Polo Shirts
- v) Casual pants and skirts
- vi) Casual shorts
- vii) Leather pumps
- viii) Casual shoes
- ix) Athletic shoes
- x) Leather boots
- xi) Gloves and hats
- xii) Sweaters and scarves

**B1b**

- i) Silk nightgowns
- ii) Cotton nightgowns
- iii) Winter pajamas
- iv) Summer pajamas
- v) Full-length slips
- vi) Half-length slips
- vii) Panties

- viii) **Girdles**
- ix) **Boxers**
- x) **Full-length pantyhose**
- xi) **Half-length pantyhose**
- xii) **Athletic socks**

**A2a**

- i) **Silk nightgowns**
- ii) **Cotton Nightgowns**
- iii) **Summer pajamas**
- iv) **Winter pajamas**
- v) **Silk full-length slips**
- vi) **Full-length slips**
- vii) **Half-length slips**
- viii) **Panties**
- ix) **Boxers**
- x) **Body slimmers**
- xi) **Full-length Pantyhose**
- xii) **Half-length Pantyhose**
- xiii) **Athletic socks**

**B2b**

- i) **Cotton/Wool Blend school coats**
- ii) **Cotton/Silk Blend dresses & suits**
- iii) **Long-sleeve and Polo shirts**
- iv) **Casual pants**
- v) **Casual shorts and skirts**
- vi) **Leather pumps**
- vii) **Casual shoes and sandals**
- viii) **Athletic shoes**
- ix) **Leather boots**
- x) **Hats and scarves**
- xi) **Sweaters**
- xii) **Gloves**

**C1a**

- i) **Classic colors bed sheets/shams**
- ii) **Plaid and patterned bed sheets/shams**
- iii) **Kid's cartoon bed sheets/shams**
- iv) **Classic colors bed skirts**
- v) **Plaid and patterned bed skirts**
- vi) **Kids cartoon bed skirts**
- vii) **Patterned and plaid wool comforters**
- viii) **Patterned and plaid silk comforters**
- ix) **Classic colors wool comforters**
- x) **Classic colors silk comforters**
- xi) **Patterned and plaid quilts**
- xii) **Classic colors quilts**

**C1b**

- i) **Air mattresses**
- ii) **Coil mattresses**
- iii) **Box spring –King/Queen Sizes**
- iv) **Box spring –Double/Single Sizes**
- v) **Convertible beds –King/Queen Sizes**
- vi) **Convertible beds –Double/Single Sizes**

- vii) **Foam Pads**
- viii) **Foam pillows**
- ix) **Posturepedic Pads**
- x) **Goosedown Pads**
- xi) **Goosedown pillows**
- xii) **Posturepedic pillows**

**C2a**

- i) **Classic colors Bathroom towels**
- ii) **Decorative Bathroom towels**
- iii) **Plaid Bathroom towels**
- iv) **Classic colors Bathroom mats**
- v) **Patterned Bathroom mats**
- vi) **Plaid Bathroom mats**
- vii) **Classic colors Contoured bath mats**
- viii) **Decorative Contoured bath mats**
- ix) **Plaid Contoured bath mats**
- x) **Classic colors Hand cloths**
- xi) **Plaid Hand cloths**
- xii) **Decorative Hand cloths**

**C2b**

- i) **Hand moisturizing & fragrant soaps**
- ii) **Body & hair shampoos**
- iii) **Bathroom towel racks**
- iv) **Medicine cabinets**
- v) **Bathroom chairs**
- vi) **Bathroom mirrors**
- vii) **Men's shavers & accessories**
- viii) **Women's shavers & accessories**
- ix) **Hairdryers**
- x) **Curling irons**
- xi) **Toothbrushes**
- xii) **Combs, & hairbrushes**

**D2a**

- i) **Cutlery holders**
- ii) **Electric knives and accessories**
- iii) **Steak knives**
- iv) **Carving knives**
- v) **Silver flatware**
- vi) **Stainless steel flatware**
- vii) **Fine China**
- viii) **Fine Crystal**
- ix) **Pots/Pans**
- x) **Baking Measuring set**
- xi) **French bistro Cooking set**
- xii) **Serve-n-store bakeware set**
- xiii) **Cookware sets and accessories**

**D2b**

- i) **Electric Juicers**
- ii) **Electric Blenders**
- iii) **Electric Mixers**
- iv) **Electric Beaters**
- v) **Stoves**

- vi) Refrigerators
- vii) Dishwashers
- viii) Microwave Ovens
- ix) Expandable kitchen tables
- x) China and wine cabinets
- xi) Kitchen stools and chairs
- xii) Kitchen storage island

**D2a**

- i) Leather sofas
- ii) Cloth sofas
- iii) Leather Sleeper sofas
- iv) Cloth sleeper sofas
- v) Leather love seats
- vi) Cloth love seats
- vii) Leather chairs
- viii) Cloth chairs
- ix) Leather dining room chairs
- x) Cloth dining room chairs
- xi) Leather recliners
- xii) Cloth recliners

**D2b**

- i) Traditional oak desks
- ii) Modern teak and glass desks
- iii) Office desks
- iv) Secretary desks
- v) Living room tables
- vi) Dining room tables
- vii) End tables
- viii) Coffee tables
- ix) Side tables
- x) Televisions, stereos & DVDs
- xi) VCRs & TV/VCR combos
- xii) Movie DVDs and CDs

**E1a**

- i) Basketball equipment
- ii) Football equipment
- iii) Baseball and softball equipment
- iv) Golf equipment
- v) Soccer equipment
- vi) Racquetball and volleyball equipment
- vii) Pool tables equipment
- viii) Table tennis equipment
- ix) Darts equipment
- x) Foosball equipment
- xi) Swimming and pool equipment
- xii) Water skiing and surfing equipment

**E1b**

- i) Kids T-ball
- ii) Kids softball equipment
- iii) Soccer equipment
- iv) Basketball equipment
- v) Kids protective T-ball/softball gear

- vi) Kids protective basketball gear
- vii) Kids protective soccer gear
- viii) Roller skating equipment
- ix) Racing bikes
- x) In-line skates
- xi) Mountain bikes
- xii) Men's and Women's touring bikes

**E2a**

- i) Gym sets
- ii) Free-weight sets
- iii) Ab-machines
- iv) Weight accessories and Exercise mats
- v) Weight-lifting books
- vi) Fat-burning books
- vii) Kids books on sports/fitness
- viii) Exercise books for children with physical disabilities
- ix) Aerobic and abs videos
- x) Tai-bo videos
- xi) Children's fun-aerobic videos

**E2b**

- i) Single person tents
- ii) Multi-person tents
- iii) 50 and 80 pound backpacks
- iv) Cooking gear
- v) Water purifiers and camp lighting
- vi) Hiking and mountain climbing maps
- vii) Hunting rifles
- viii) Hunting knives
- ix) Fishing rods and reels
- x) Hunting outfits
- xi) Fishing outfits
- xii) Fishing gear

**F1a**

- i) Outdoor swings
- ii) Kids teeter totters
- iii) Wooden play houses
- iv) Plastic play houses
- v) Jungle-gyms
- vi) 2-person trampolines
- vii) 4-person trampolines
- viii) Gas barbecue Grills
- ix) Electric barbecue Grills
- x) Smoker barbecue Grills
- xi) Kettle barbecue Grills
- xii) Grill covers and rotisseries

**F1b**

- i) Gardening tools
- ii) Gardening seeds
- iii) Garden flowers
- iv) Garden baskets
- v) Patio chairs
- vi) Patio tables

- vii) **Patio umbrellas**
- viii) **Hammocks**
- ix) **Lawn darts**
- x) **Croquet**
- xi) **Lawn lighting**
- xii) **Lawn accessories**

**G1a**

- i) **Gameboy**
- ii) **Sony Playstation**
- iii) **Electric riding toys**
- iv) **Remote-controlled toys**
- v) **Video games**
- vi) **Interactive toys**
- vii) **Electronic board games**
- viii) **Stamp and Coin collection kits**
- ix) **Discovery Jr. science and electronics labs**
- x) **Paint sets and art easels**
- xi) **Discovery ant forms**
- xii) **Kids telescopes and microscopes**

**G1b**

- i) **Toy cars and trucks**
- ii) **Army Toys**
- iii) **Bath toys**
- iv) **Big wheel**
- v) **Board games**
- vi) **Barbies**
- vii) **Action & Movie figures**
- viii) **Teddy bears**
- ix) **Books for Preschoolers**
- x) **Books for Post-elementary children**
- xi) **Music for children**
- xii) **Movies for children and families**

*The (3 x 2 x 2 x 2 x 12) Hypertext Condition*

**1st Level**

- A) Apparel**
- B) Home Interiors**
- C) Leisure/Fitness Items**

**2nd Level**

**A**

- 1) Male apparel**
- 2) Female apparel**

**B**

- 1) Bed & Bath**
- 2) Kitchen & Living Room**

**C**

- 1) Sports/The Outdoors**
- 2) Toys & backyard fun**

**3rd Level**

**A1**

- a) Men's apparel**
- b) Boy's apparel**

**A2**

- a) Women's apparel**
- b) Girl's apparel**

**B1**

- a) Bedroom**
- b) Bathroom**

**B2**

- a) Kitchen**
- b) Furniture/Entertainment**

**C1**

- a) Sports**
- b) Exercise/The Outdoors**

**C2**

- a) Backyard fun**
- b) Toys and Games**

**4th Level**

**A1a**

- i) Clothing and accessories**
- ii) Undergarments & sleepwear**

**A1b**

- i) **Undergarments & sleepwear**
- ii) **Clothing and accessories**

**A2a**

- i) **Undergarments & sleepwear**
- ii) **Clothing and accessories**

**A2b**

- i) **Undergarments & sleepwear**
- ii) **Clothing and accessories**

**B1a**

- i) **Bedding linen**
- ii) **Beds & Accessories**

**B1b**

- i) **Bathroom linen**
- ii) **Bathroom accessories**

**B2a**

- i) **Table/Kitchenware**
- ii) **Kitchen appliances and furniture**

**B2b**

- i) **Seating**
- ii) **Desks, Tables & Electronics**

**C1a**

- i) **Team, indoor, and water sports**
- ii) **Kid's sports and bikes/skates**

**C1b**

- i) **Exercise/fitness equipment**
- ii) **Hiking/Climbing and Hunting/Fishing**

**C2a**

- i) **Kid's playgrounds and grilling**
- ii) **Gardening and lawn items**

**C2b**

- i) **Electronic/video games, hobbies, arts/crafts, and educational toys**
- ii) **Toys, games, figures, books, music, and movies for kids and family**

**5th Level**

**A1ai**

- 1) **Cotton/Wool Blend sports coat**
- 2) **Cotton/Wool Blend suits**
- 3) **Cotton/Wool Blend trousers**
- 4) **Long-sleeve and Polo shirts**
- 5) **Causal shorts and pants**
- 6) **Oxford dress shoes**
- 7) **Casual shoes and sandals**
- 8) **Athletic shoes**
- 9) **Cowboy boots**

- 10) Hats and scarves
- 11) Sweaters
- 12) Gloves

#### **A1aii**

- 1) Summer Pajamas
- 2) Winter Pajamas
- 3) Patterned v-neck undershirts
- 4) Classic colors v-neck undershirts
- 5) Patterned crewneck undershirts
- 6) Classic colors crewneck undershirts
- 7) Silk boxer shorts
- 8) Cotton boxer shorts
- 9) Sports briefs
- 10) Regular briefs
- 11) Athletic and tube socks
- 12) Dress socks

#### **A1bi**

- 1) Summer Pajamas
- 2) Winter Pajamas
- 3) Patterned v-neck undershirts
- 4) Classic colors v-neck undershirts
- 5) Patterned crewneck undershirts
- 6) Classic colors crewneck undershirts
- 7) Silk boxer shorts
- 8) Cotton boxer shorts
- 9) Sports briefs
- 10) Regular briefs
- 11) Athletic and tube socks
- 12) Dress socks

#### **A1bii**

- 1) Cotton/Wool Blend school coats
- 2) Cotton/Wool Blend dress suits
- 3) Cotton/Wool Blend trousers
- 4) Long-sleeve and Polo shirts
- 5) Casual pants and shorts
- 6) Dress shoes
- 7) Casual shoes and sandals
- 8) Athletic shoes
- 9) Cowboy boots
- 10) Gloves
- 11) Hats and scarves
- 12) Sweaters

#### **A2bi**

- 1) Silk nightgowns
- 2) Cotton nightgowns
- 3) Summer pajamas
- 4) Winter pajamas
- 5) Full-length slips
- 6) Half-length slips
- 7) Panties
- 8) Girdles
- 9) Boxers

- 10) Full-length pantyhose
- 11) Half-length pantyhose
- 12) Athletic socks

**A2aii**

- 1) Business dresses and suits
- 2) Evening and prom dresses
- 3) Long-sleeve shirts
- 4) Polo Shirts
- 5) Casual pants and skirts
- 6) Casual shorts
- 7) Leather pumps
- 8) Casual shoes
- 9) Athletic shoes
- 10) Leather boots
- 11) Gloves and hats
- 12) Sweaters and scarves

**A2Bi**

1. Silk nightgowns
2. Cotton Nightgowns
3. Summer pajamas
4. Winter pajamas
5. Full-length slips
6. Half-length slips
7. Panties
8. Boxers
9. Body slimmers
10. Full-length Pantyhose
11. Half-length pantyhose
12. Athletic socks

**A2bii**

1. Cotton/Wool Blend school coats
2. Cotton/Silk Blend dresses & suits
3. Long-sleeve and Polo shirts
4. Casual pants
5. Casual shorts and skirts
6. Leather pumps
7. Casual shoes and sandals
8. Athletic shoes
9. Leather boots
10. Hats and scarves
11. Sweaters
12. Gloves

**B1ai**

- 1) Classic colors bed sheets/shams
- 2) Plaid and patterned bed sheets/shams
- 3) Kid's cartoon bed sheets/shams
- 4) Classic colors bed skirts
- 5) Plaid and patterned bed skirts
- 6) Kids cartoon bed skirts
- 7) Patterned and plaid wool comforters
- 8) Patterned and plaid silk comforters
- 9) Classic colors wool comforters

- 10) Classic colors silk comforters
- 11) Patterned and plaid quilts
- 12) Classic colors quilts

**B1aii**

1. Air mattresses
2. Coil mattresses
3. Box spring –King/Queen Sizes
4. Box spring –Double/Single Sizes
5. Convertible beds –King/Queen Sizes
6. Convertible beds –Double/Single Sizes
7. Foam Pads
8. Foam pillows
9. Posturepedic Pads
10. Goosedown Pads
11. Goosedown pillows
12. Posturepedic pillows

**B1bi**

1. Classic colors Bathroom towels
2. Decorative Bathroom towels
3. Plaid Bathroom towels
4. Classic colors Bathroom mats
5. Decorative Bathroom mats
6. Plaid Bathroom mats
7. Classic colors Contoured bath mats
8. Decorative Contoured bath mats
9. Plaid Contoured bath mats
10. Classic colors Hand cloths
11. Plaid Hand cloths
12. Decorative Hand cloths

**B1bii**

1. Hand moisturizing & fragrant soaps
2. Body & hair shampoos
3. Bathroom towel racks
4. Medicine cabinets
5. Bathroom chairs
6. Bathroom mirrors
7. Men's shavers & accessories
8. Women's shavers & accessories
9. Hairdryers
10. Curling irons
11. Toothbrushes
12. Combs & hairbrushes

**B2ai**

1. Cutlery holders
2. Electric knives and accessories
3. Steak knives
4. Carving knives
5. Silver flatware
6. Stainless steel flatware
7. Waterford Fine China
8. Waterford Fine Crystal
9. Baking Measuring set

10. French bistro Cooking set
11. Serve-n-store bakeware set
12. Cookware sets and accessories
13. Pots/pans

**B2bii**

1. Electric Juicers
2. Electric Blenders
3. Electric Mixers
4. Electric Beaters
5. Stoves
6. Refrigerators
7. Dishwashers
8. Microwave Ovens
9. Expandable kitchen tables
10. China and wine cabinets
11. Kitchen stools and chairs
12. Kitchen storage island

**B2bi**

1. Leather sofas
2. Cloth sofas
3. Leather sleeper sofas
4. Cloth sleeper sofas
5. Leather love seats
6. Cloth love seats
7. Leather chairs
8. Cloth chairs
9. Leather recliners
10. Cloth Recliners
11. Leather dining room chairs
12. Cloth dining room chairs

**B2bii**

1. Traditional oak desks
2. Modern oak desks
3. Computer/Office desks
4. Secretary desks
5. Side tables
6. Coffee tables
7. End tables
8. Dining room tables
9. Living room tables
10. Televisions, Stereos & DVDs
11. VCRs & TV/VCR Combos
12. Movie DVDs & CDs

**C2ai**

1. Basketball equipment
2. Football equipment
3. Baseball and softball equipment
4. Foosball equipment
5. Golf equipment
6. Soccer equipment
7. Racquetball and volleyball equipment
8. Swimming and pool equipment

9. Water skiing and surfing equipment
10. Pool table equipment
11. Table tennis equipment
12. Darts equipment

**C2aii**

- 1) Kids T-ball
- 2) Kids softball equipment
- 3) Soccer equipment
- 4) Basketball equipment
- 5) Kids protective T-ball and softball gear
- 6) Kids protective basketball gear
- 7) Kids protective soccer gear
- 8) Roller Skating equipment
- 9) Racing bikes
- 10) In-line skates
- 11) Mountain bikes
- 12) Men's and Women's touring bikes

**C1bi**

- 1) Gym sets
- 2) Free-weight sets
- 3) Ad-machines
- 4) Weight accessories and Exercise mats
- 5) Aerobic and Abs videos
- 6) Tai-bo videos
- 7) Weight-lifting books
- 8) Fat-Burning books
- 9) Children's fun-aerobic videos
- 10) Exercise books for children with physical Disabilities
- 11) Exercise videos for preschoolers
- 12) Kids beginning books on sports/fitness

**C1bii**

- 1) Single person tents
- 2) Multi-person tents
- 3) 50 and 80 pound backpacks
- 4) Cooking gear
- 5) Water purifiers and camp lighting
- 6) Hiking and mountain climbing maps
- 7) Hunting rifles
- 8) Hunting knives
- 9) Fishing rods and reels
- 10) Hunting outfits
- 11) Fishing outfits
- 12) Fishing tackle

**C2ai**

- 1) Outdoor swings
- 2) Kids teeter totters
- 3) Wooden play houses
- 4) Plastic play houses
- 5) Jungle-gyms
- 6) 2-person trampolines
- 7) 4-person trampolines
- 8) Gas barbecue Grills

- 9) Electric barbecue Grills
- 10) Smoker barbecue Grills
- 11) Kettle barbecue Grills
- 12) Grill covers and rotisseries

**C2aii**

- 1) Gardening tools
- 2) Gardening seeds
- 3) Garden flowers
- 4) Garden baskets
- 5) Patio chairs
- 6) Patio tables
- 7) Patio umbrellas
- 8) Hammocks
- 9) Lawn darts
- 10) Croquet
- 11) Lawn lighting
- 12) Lawn accessories

**C2bi**

- 1) Gameboy
- 2) Sony Playstation
- 3) Electric riding toys
- 4) Remote-controlled toys
- 5) Video games
- 6) Interactive toys
- 7) Electronic board games
- 8) Stamp and Coin collecting kits
- 9) Discovery Jr. science and electronics labs
- 10) Paint sets and art easels
- 11) Discovery ant forms
- 12) Kids telescopes and microscopes

**C2bii**

- 1) Toy Cars & Trucks
- 2) Army toys
- 3) Bath Toys
- 4) Big Wheel
- 5) Board Games
- 6) Barbies
- 7) Action & Movie Figures
- 8) Teddy Bears
- 9) Books for Preschoolers
- 10) Books for Post-elementary children
- 11) Music for children
- 12) Movies for children and families

*The (3 x 2 x 3 x 2 x 3 x 2) Hypertext Condition*

**1st Level**

- A) **Apparel**
- B) **Home Interiors**
- C) **Leisure/Fitness Items**

**2nd Level**

**A**

- 1) **Male apparel**
- 2) **Female apparel**

**B**

- 1) **Bed & Bath**
- 2) **Kitchen & Furnishings**

**C**

- 1) **Sports/The Outdoors**
- 2) **Toys & backyard fun**

**3rd Level**

**A1**

- a) **Clothing & Accessories**
- b) **Footwear and Winter accessories**
- c) **Sleepwear and Undergarments**

**A2**

- a) **Clothing & Accessories**
- b) **Footwear, and winter accessories**
- c) **Sleepwear and undergarments**

**B1**

- a) **Bedding linens**
- b) **Beds & Accessories**
- c) **Bathroom linens, toiletries, and accessories**

**B2**

- a) **Kitchenware**
- b) **Kitchen furniture and appliances**
- c) **Furniture and Entertainment**

**C1**

- a) **Sports**
- b) **Exercise and The outdoors**
- c) **Kids sporting equipment and accessories**

**C2**

- a) **Toys/Games**
- b) **Playgrounds and patio furniture**
- c) **Grilling, gardening, and lawn accessories**

#### 4th Level

##### A1a

- i) Men's clothing
- ii) Boy's clothing

##### A1b

- i) Men's footwear and Winter accessories
- ii) Boy's footwear and Winter accessories

##### A1c

- i) Men's sleepwear and Undergarments
- ii) Boy's sleepwear and Undergarments

##### A2a

- i) Women's clothing
- iii) Girl's clothing

##### A2b

- i) Women's footwear, and Winter accessories
- ii) Girl's footwear, and Winter accessories

##### A2c

- i) Women's Undergarments
- ii) Girl's Undergarments

##### B1a

- i) Bed sheets
- ii) Comforters and quilts

##### B1b

- i) Beds
- ii) Pads & pillows

##### B1c

- i) Bathroom linens
- ii) Toiletries, and accessories

##### B2a

- i) Cutlery
- ii) Dishware and cookware

##### B2b

- i) Kitchen furnishings
- ii) Kitchen appliances

##### B2c

- i) Interior furniture
- ii) Entertainment accessories

##### C1a

- i) Outdoor sports
- ii) Indoor team and water sports

**C1b**

- i) Exercise equipment**
- ii) Camping, hunting, and fishing equipment**

**C1c**

- i) Kid's sports equipment**
- ii) Kid's exercise/fitness equipment**

**C2a**

- i) Electronic/video, hobbies, arts/crafts**
- ii) Infant to pre-teen toys**

**C2b**

- i) Playgrounds**
- ii) Patio furniture**

**C2c**

- i) Barbecue grills and accessories**
- ii) Gardening and backyard games**

**5th Level**

**A1ai**

- 1) Suits and fitted shirts**
- 2) Sports coats and trousers**
- 3) Casuals**

**A1aii**

- 1) Suits, and fitted shirts**
- 2) School outfits**
- 3) Casuals**

**A1bi**

- 1) Dress shoes and boots**
- 2) Casual/Sports shoes**
- 3) Winter Accessories**

**A1bii**

- 1) Dress shoes and boots**
- 2) Casual/Sports Shoes**
- 3) Winter Accessories**

**A1ci**

- 1) Underwear and socks**
- 2) Undershirts**
- 3) Pajamas**

**A1cii**

- 1) Underwear and socks**
- 2) Undershirts**
- 3) Pajamas**

**A2ai**

- 1) Business outfits**
- 2) Formal dresses**
- 3) Casuals**

**A2aii**

- 1) Formal school outfits
- 2) Dresses and suits
- 3) Casuals

**A2bi**

- 1) Dress shoes and boots
- 2) Casuals/Sports shoes
- 3) Winter accessories

**A2bii**

- 1) Dress shoes and boots
- 2) Casual/Sports shoes
- 3) Winter accessories

**A2ci**

- 1) Pajamas/Nightgowns
- 2) Slips, hosiery/socks
- 3) Underwear

**A2cii**

- 1) Sleepwear
- 2) Slips, hosiery/socks
- 3) Underwear

**B1ai**

- 1) Bed sheets
- 2) Bed skirts
- 3) Bed shams

**B1aii**

- 1) Silk comforters
- 2) Wool comforters
- 3) Quilted comforters

**B1bi**

- 1) Mattresses
- 2) Box spring
- 3) Convertible beds

**B1bii**

- 1) Foam Pads & pillows
- 2) Goosedown pads & pillows
- 3) Posturepedic pads & pillows

**B1ci**

- 1) Bathroom towels
- 2) Bathroom mats
- 3) Hand cloths

**B1cii**

- 1) Soaps/Shampoos
- 2) Bathroom furniture
- 3) Bathroom accessories

**B2ai**

- 1) **Kitchen and Dining knives**
- 2) **Flatware and accessories**
- 3) **Electric knives and accessories**

**B2aii**

- 1) **Fine china and crystal**
- 2) **Ovenware**
- 3) **Stoveware and measuring sets**

**B2bi**

- 1) **Kitchen cabinets**
- 2) **Kitchen tables**
- 3) **Kitchen seating**

**B2bii**

- 1) **Hand-Held Electric Appliances**
- 2) **Cooking appliances**
- 3) **Large Appliances**

**B2ci**

- 1) **Sofas**
- 2) **Chairs**
- 3) **Desks/Tables**

**B12cii**

- 1) **TVs and Stereos**
- 2) **VCR/DVD players**
- 3) **DVDs and CD**

**C1ai**

- 1) **Team sports**
- 2) **Golf equipment**
- 3) **Bicycles and scooters**

**C1aii**

- 1) **Water Sports**
- 2) **Billiard & table tennis equipment**
- 3) **Foosball and racquetball equipment**

**C1bi**

- 1) **Gyms and exercise equipment**
- 2) **Fitness videos**
- 3) **Fitness books**

**C1bii**

- 1) **Tents and camping accessories**
- 2) **Backpacks**
- 3) **Hunting/fishing equipment and accessories**

**C1ci**

- 1) **Kids T-ball and Softball equipment**
- 2) **Kids soccer and basketball equipment**
- 3) **Kids skating equipment**

**C1cii**

- 1) **Children's sports protective gear**
- 2) **Children's fitness videos**
- 3) **Children's fitness books**

**C2ai**

- 1) **Kids Electronic/videos**
- 2) **Kids Hobby/science, Arts and crafts**
- 3) **Kids toys**

**C2aii**

- 1) **Games and Dolls**
- 2) **Books, Music and Movies**
- 3) **Outdoor and bath toys**

**C2bi**

- 1) **Swings/teeter totters**
- 2) **Jungle-gyms and Trampolines**
- 3) **Play houses**

**C2bii**

- 1) **Patio chairs & tables**
- 2) **Hammocks**
- 3) **Umbrellas**

**C2ci**

- 1) **Gas and electric barbecue grills**
- 2) **Wood-Fired barbecue grills**
- 3) **Grill accessories**

**C2cii**

- 1) **Garden baskets**
- 2) **Gardening items**
- 3) **Lawn games**

**6th Level**

**A1ai1**

- a) **Wool/Cotton Blend suits**
- b) **Long-sleeve shirts**

**A1ai2**

- a) **Wool/Cotton Blend sports coats**
- b) **Wool/Cotton Blend trousers**

**A1ai3**

- a) **Casual Polo shirts**
- b) **Casual shorts and pants**

**A1aii1**

- a) **Wool/Cotton Blend suits**
- b) **Long-sleeve shirts**

**A1aii2**

- a) **Wool/Cotton Blend school coats**
- b) **Suits**

**A1aii3**

- a) Polo shirts
- b) Shorts and pants

**A1bi1**

- a) Oxford dress shoes
- b) Western boots

**A1bi2**

- a) Casual shoes
- b) Athletic shoes and sandals

**A1bi3**

- a) Gloves and hats
- b) Sweaters and scarves

**A1bii1**

- a) Oxford dress shoes
- b) Western boots

**A1bii2**

- a) Casual shoes
- b) Athletic shoes and sandals

**A1bii3**

- a) Gloves and hats
- b) Sweaters and scarves

**A1ci1**

- a) Boxers and briefs
- b) Athletic, tube, and dress socks

**A1ci2**

- a) V-neck undershirts
- b) Crewneck undershirts

**A2ci3**

- a) Summer pajamas
- b) Winter pajamas

**A1cii1**

- a) Boxers and briefs
- b) Athletic, tube, and dress socks

**A1cii2**

- a) V-neck undershirts
- b) Crewneck undershirts

**A1cii3**

- a) Summer pajamas
- c) Winter pajamas

**A2ai1**

- a) Business dresses
- b) Business suits

**A2ai2**

- a) Evening dresses
- b) Prom dresses

**A2ai3**

- a) Polo shirts
- b) Casual shorts, skirts, and pants

**A2aii1**

- a) Cotton Blend School coats
- b) Wool Blend School Coats

**A2aii2**

- a) Cotton/Silk Blend Dresses
- b) Cotton/Silk Blend suits

**A2aii3**

- a) Polo shirts
- b) Casual shorts, Skirts, and pants

**A2bi1**

- a) Leather pumps
- b) Leather boots

**A2bi2**

- a) Casual shoes, and sandals
- b) Athletic shoes

**A2bi3**

- a) Gloves and hats
- b) Sweaters and scarves

**A2bii1**

- a) Leather pumps
- b) Justin boots

**A2bii2**

- a) Casual shoes and sandals
- b) Athletic shoes

**A2bii3**

- a) Gloves and hats
- b) Sweaters and scarves

**A2ci1**

- a) Cotton/Silk nightgowns
- b) Cotton/Silk pajamas

**A2ci2**

- a) Full and half-length slips
- b) Pantyhose and athletic socks

**A2ci3**

- a) Panties and boxers
- b) Girdles

**A2cii1**

- a) Cotton/Silk nightgowns
- b) Cotton/Silk pajamas

**A2cii2**

- a) Full and half-length slippers
- b) Pantyhose and athletic socks

**A2cii3**

- a) Panties boxers
- b) Body slimmers

**B1ai1**

- a) Decorative and Cartoon sheets
- b) Classic colors sheets

**B1ai2**

- a) Decorative and Cartoon skirts
- b) Classic colors skirts

**B1ai3**

- a) Decorative and Cartoon shams
- b) Classic colors shams

**B1aii1**

- a) Decorative and Cartoon silk comforters
- b) Classic colors silk comforters

**B1aii2**

- a) Decorative and Cartoon wool comforters
- b) Classic colors wool comforters

**B1aii3**

- a) Decorative and Cartoon quilted comforters
- b) Classic colors quilted comforters

**B1bi1**

- a) Coil mattresses
- b) Air mattresses

**B1bi2**

- a) Box spring – King and queen sizes
- b) Box spring – Double to single sizes

**B1bi3**

- a) Convertible Beds – King and queen sizes
- b) Convertible Beds – Double to single sizes

**B1bii1**

- a) Foam Pads & pillows – King and queen sizes
- b) Foam Pads & pillows – Double to single sizes

**B1bii2**

- a) Goosedown Pads & pillows – King and queen sizes
- b) Goosedown Pads & pillows – Double to single sizes

**B1bii3**

- a) Posturepedic Pads & pillows – King and queen sizes
- b) Posturepedic Pads & pillows –Double to single sizes

**B1bci1**

- a) Decorative bathroom towels
- b) Classic colors bathroom towels

**B1bci2**

- a) Decorative bathroom mats
- b) Classic colors bathroom mats

**B1bci3**

- a) Decorative hand cloths
- b) Classic colors hand cloths

**B1cii1**

- a) Fragrant & Moisturizing soaps
- b) Hair and Body shampoos

**B1cii2**

- a) Towl racks/Cabinets
- b) Chairs and Mirrors

**B1cii3**

- a) Men's and women's shavers & accessories
- b) Hairdryers, combs, and hairbrushes

**B2ai1**

- a) Pairing, Cleavers, and carving knives
- b) Steak knives

**B2ai2**

- a) Silver/stainless steel flatware
- b) Cutlery holders

**B2ai3**

- a) Electric knives
- b) Electric knives blades and attachments

**B2aii1**

- a) Waterford Fine china
- b) Waterford Fine crystal

**B2aii2**

- a) French bistro cooking set
- b) Serve-n-store bakeware set

**B2aii3**

- a) Baking measuring set
- b) T-Fal Pots and pans

**B2bi1**

- a) Wine cabinets
- b) China cabinets

**B2bi2**

- a) Expandable Kitchen tables
- b) Kitchen islands tables

**B2bi3**

- a) Bar Stools
- b) Kitchen chairs

**B2bii1**

- a) Blenders & mixers
- b) Juicers

**B2bii2**

- a) Stoves
- b) Microwave ovens

**B2bii3**

- a) Dishwashers
- b) Refrigerators

**B2ci1**

- c) Traditional Sofas and sleeper sofas
- d) Love seats

**B2ci2**

- a) Chairs
- b) Recliners

**B2ci3**

- a) Computer/Office Desks
- a) Dining room/Coffee tables

**B2cii1**

- c) Sony TVs
- a) Sony Home Stereos

**B2cii2**

- c) Panasonic VDRs
- a) Panasonic DVD players

**B2cii3**

- c) Popular Movie DVDs
- a) Popular CDs

**C1ai1**

- a) Basketball, football, and soccer equipment
- b) Baseball, softball, and volleyball equipment

**C1ai2**

- a) Golf clubs
- b) Golf accessories

**C1ai3**

- a) Racing and touring bikes
- b) Mountain bikes

**C1aii1**

- a) **Swimming equipment**
- b) **Pool, and water sports equipment**

**C1aii2**

- a) **Billiard equipment**
- b) **Table tennis equipment**

**C1aii3**

- a) **Foosball equipment**
- b) **Racquetball equipment**

**C1bi1**

- a) **Gym sits**
- b) **Free-weight sets**

**C1bi2**

- a) **Aerobic and Abs videos**
- b) **Tai-bo videos**

**C1bi3**

- a) **Weight-lifting books**
- b) **Fat-burning books**

**C1bii1**

- a) **Single and multi-person tents**
- b) **Cooking gear, water purifiers, and camp lighting**

**C1bii2**

- a) **50 pound backpacks**
- b) **80 pound backpacks**

**C1bii3**

- a) **Fishing rods/reels and accessories**
- b) **Hunting rifles/knives and accessories**

**C1ci1**

- a) **Kid's T-ball equipment**
- b) **Kid's Softball equipment**

**C1ci2**

- a) **Kids soccer equipment**
- b) **Kids basketball equipment**

**C1ci3**

- a) **Kids in-line skates**
- b) **Kid's roller skates**

**C1cii1**

- a) **Kids T-ball/softball protective gear**
- b) **Kids Soccer and basketball protective gear**

**C1cii2**

- a) **Kids fun-aerobic videos**
- b) **Exercise videos for preschoolers**

**C1cii3**

- a) Kids beginning books on sports/fitness
- b) Exercise books for children with physical disabilities

**C2ai1**

- a) Gameboy, Sony Playstation, and videos
- b) Electronic board games and interactive toys

**C2ai2**

- a) Stamp and Coin collecting kits, science labs
- b) Art easels/paint sets

**C2ai3**

- a) Action and movie figures
- b) Army toys, toy cars and trucks

**C2aii1**

- a) Barbies and Teddy Bears
- b) Infant/developmental toys and games

**C2aii2**

- a) Books for the family
- b) Music and movies for the family

**C2aii3**

- a) Big Wheels
- b) Bath toys

**C2bi1**

- a) Stationary and rope swings
- b) Teeter totters

**C2bi2**

- a) Jungle-gyms
- b) Trampolines

**C2bi3**

- a) 2-person play houses
- b) 4-person play houses

**C2bii1**

- a) Patio Chairs
- b) Patio tables

**C2bii2**

- a) Hammocks
- b) Hammock accessories

**C2bii3**

- a) 3-foot umbrellas
- b) 4-foot umbrellas

**C2ci1**

- a) Gas barbecue grills
- b) Electric barbecue grills

**C2ci2**

- a) **Smoker barbecue grills**
- b) **Kettle barbecue grills**

**C2ci3**

- a) **Grill covers**
- b) **Grilling rotisseries**

**C2cii1**

- a) **Wicker garden baskets**
- b) **Copper garden baskets**

**C2cii2**

- a) **Gardening tools**
- b) **Flower and seeds**

**C2cii3**

- a) **Lawn darts**
- b) **Croquet**

